



DIGIRAIL OEE

USER GUIDE V1.2x F

NOVUS
We Measure, We Control, We Record



Recommended for devices with firmware version V 1.23 and higher.

**ELEKTRO
VÁLVULAS**
SEGURIDAD Y CONTROL EN COMBUSTIÓN

ANATEL
09260-20-07089

CE

**UK
CA**

FC

1	SAFETY ALERTS	4
2	PRESENTATION	5
3	IDENTIFICATION	6
3.1	DEVICE OVERVIEW	6
3.2	DEVICE IDENTIFICATION	6
3.3	DEVICE MODEL	6
4	INSTALLATION	7
4.1	MECHANICAL INSTALLATION	7
4.1.1	DIMENSION	8
4.2	ELECTRICAL INSTALLATION	9
4.2.1	POWER SUPPLY	9
4.2.2	DIGITAL INPUT	10
4.2.3	ANALOG INPUT	10
4.2.4	DIGITAL OUTPUT	11
4.3	LED INDICATORS	11
5	COMMUNICATION INTERFACES	12
5.1	USB INTERFACE	12
5.2	RS485 INTERFACE	12
5.3	ETHERNET INTERFACE	13
5.4	WI-FI INTERFACE	13
6	MQTT PROTOCOL	14
6.1	PUBLICATION AND SUBSCRIPTION TOPICS	14
6.2	PUBLISH BASIC MODEL	14
6.3	TRANSMISSION MODEL FOR DATA AND EVENTS	14
6.2.1	DATA AND EVENTS	14
6.2.2	CHANNEL DATA	14
6.2.3	EVENTS	15
6.4	CONFIGURATION	15
6.3.1	TRANSMISSION MODEL FOR CONFIGURATIONS AND COMMANDS	16
6.5	COMMANDS	16
6.4.1	OUTPUT	16
6.4.2	RESET COUNTERS	17
6.4.3	SET COUNTERS	18
6.4.4	GET DIAGNOSTIC	19
6.4.5	GATEWAY MQTT RS485	21
6.4.6	RESET DIAGNOSTIC	22
6.4.7	LOGS	22
6.4.8	LOGS_PARSED	23
7	MODBUS-TCP PROTOCOL	25
7.1	COMMANDS	25
7.2	REGISTERS TABLE	25
8	CONFIGURATION SOFTWARE	31
8.1	CONFIGURING DIGIRAIL OEE WITH NXPERIENCE	31
8.1.1	GENERAL SETTINGS	31
8.1.2	COMMUNICATION	32
8.1.3	CHANNELS	36
8.1.4	LOGS	38
8.2	DIAGNOSTICS	38
8.2.1	INFORMATION	38
8.2.2	INPUTS	39
8.2.3	OUTPUTS	39



8.2.4	CONNECTIVITY	40
8.2.5	SYSTEM EVENTS.....	41
9	TECHNICAL SPECIFICATION	42
9.1	CIRCULAR BUFFER AVAILABILITY TABLE	43
9.2	WIRELESS CONNECTIVITY.....	43
9.3	CERTIFICATION	44
10	WARRANTY	45
11	APPENDIX 1 – RECOMMENDATIONS FOR INSTALLATION IN INDUSTRIAL ENVIRONMENTS.....	46
11.1	PURPOSE	46
11.2	BEST PRACTICES FOR INDUSTRIAL INSTALLATION	46
11.3	INSTALLATION RECOMMENDATIONS FOR DIGIRAIL OEE DIGITAL INPUT SIGNALS	46
11.3.1	ISOLATED GROUND POWER SUPPLY	46
11.3.2	PULL-UP RESISTORS FOR THE SENSORS.....	47
11.3.3	HOW TO GROUND THE NEGATIVE TERMINAL OF THE POWER SUPPLY.....	47
11.3.4	GROUNDED CONDUIT.....	48

ELEKTRO VÁLVULAS

SEGURIDAD Y CONTROL EN COMBUSTIÓN

1 SAFETY ALERTS

The symbols below are used in the device and throughout this manual to draw the user's attention to important information related to device safety and use.

		
CAUTION Read the manual fully before installing and operating the device.	CAUTION OR HAZARD Risk of electric shock.	ATTENTION Material sensitive to static charge. Check precautions before handling.

All safety recommendations appearing in this manual must be followed to ensure personal safety and prevent damage to the instrument or system. If the instrument is used in a manner other than that specified in this manual, the device's safety protections may not be effective.

ELEKTRO
VÁLVULAS
SEGURIDAD Y CONTROL EN COMBUSTIÓN

2 PRESENTATION

DigiRail OEE is the ideal tool to read the sensors that monitor the operation of machines, devices, or processes. Among its many applications, this multi-input module allows you to account operation time and stand-by time and the amount of approved and rejected parts, indicates the need for preventive or corrective maintenance, or monitor operating conditions in general.

The device has 6 digital inputs, 2 analog inputs and 2 digital outputs, RS485 interface, USB interface, Wi-Fi or Ethernet communication interface and is compatible with the main clouds on the market. In addition, it can be integrated with MES, SCADA, and ERP systems.

The figure below shows an example of topology for **DigiRail OEE**:

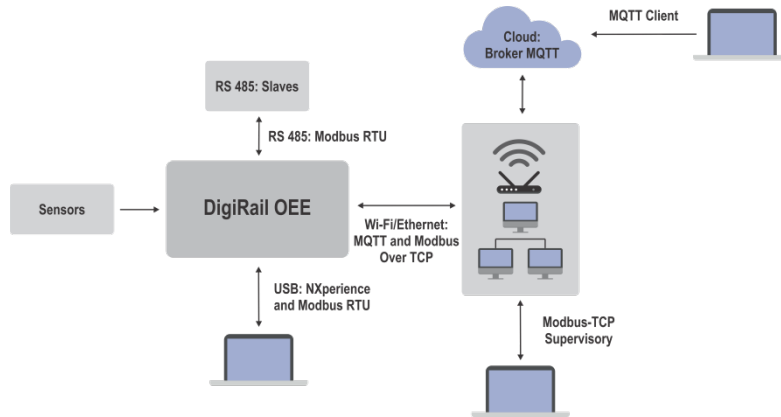

Figure 1 – Topology

ELEKTRO VÁLVULAS

SEGURIDAD Y CONTROL EN COMBUSTIÓN

3 IDENTIFICATION

3.1 DEVICE OVERVIEW

Built in ABS+PC and with IP20 protection rating, **DigiRail OEE** has high quality housing, three LEDs on its front and a protection cover with detachable faces to pass the sensors, as shown in the figure below:

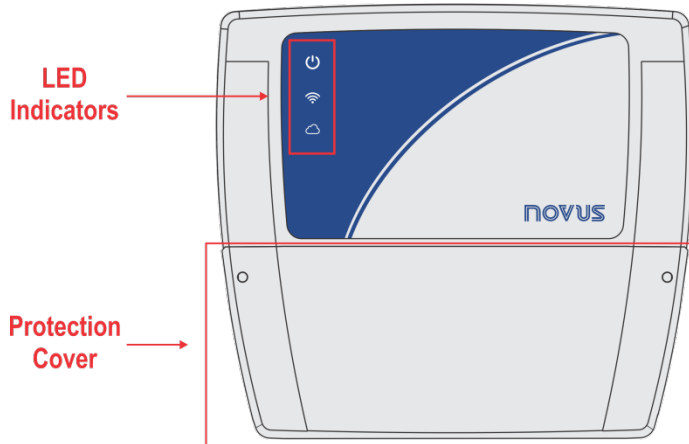

Figure 2 – Device overview

3.2 DEVICE IDENTIFICATION

The identification of the device model is described on the label attached to the back of the housing. This label also provides information on the power supply, MAC address and serial number, as shown in the figure below:

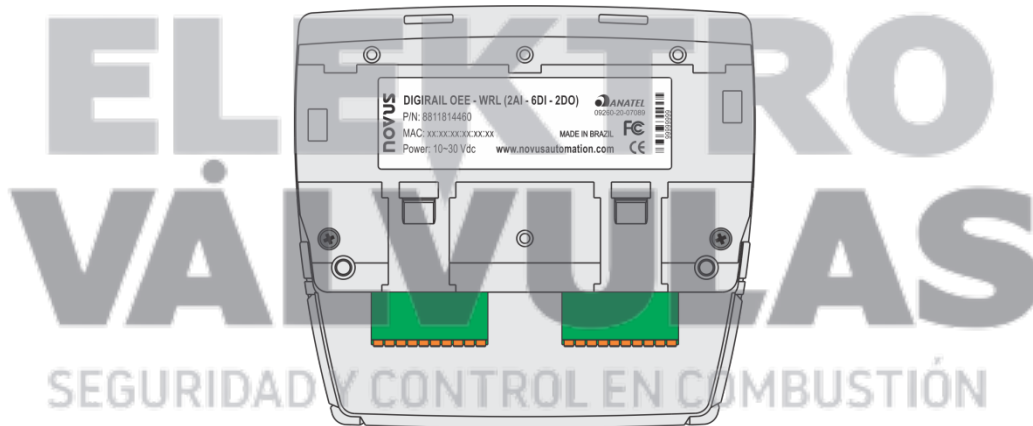

Figure 3 – DigiRail OEE

3.3 DEVICE MODEL

DigiRail OEE has two models: **DigiRail OEE – WRL** and **DigiRail OEE – ETH**. Its features are described in **Table 01**:

	Digital Input	Analog Input	Digital Output	USB Interface	RS485 Communication Interface	Ethernet Communication Interface	Wireless Communication Interface
WRL	6	2	2	1	1	x	1
ETH	6	2	2	1	1	1	x

Table 1 – DigiRail OEE models

4 INSTALLATION

4.1 MECHANICAL INSTALLATION

As shown in the figure below, **DigiRail OEE** can be installed on DIN 35 mm rail. You must fix it with its back clips:



Figure 4 – DIN rail installation

In addition, the device also has two holes to fix it with screws, as shown in the figure below:

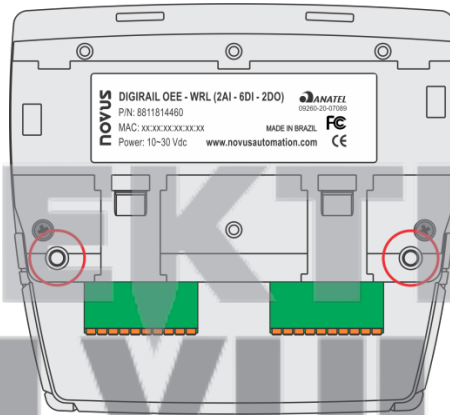

Figure 5 – Installation with screws

DigiRail OEE has a removable protection cover to protect its connection terminals. The protection cover has three detachable areas, one at the bottom and one at each side, so you can easily handle the sensors:

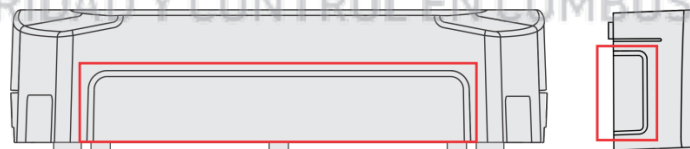

Figure 6 – Detachable areas of the protection cover

The protection cover has two pins, located on the sides of the housing, which help you fit it into the device. Once the cover has been installed, you will need a screwdriver to remove it.

4.1.1 DIMENSION

DigiRail OEE has the following dimensions:

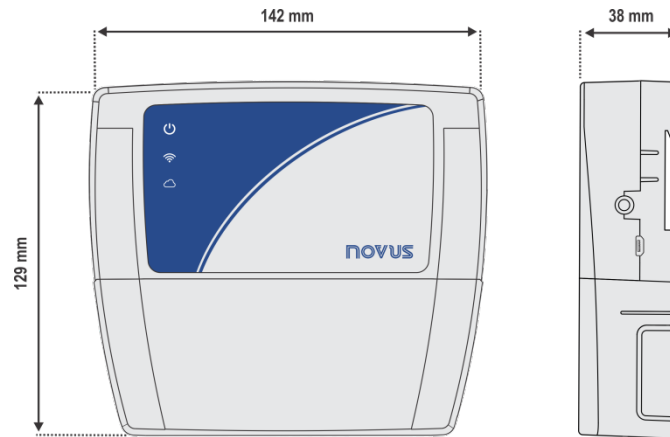

Figure 7 – Device dimensions with the protection cover

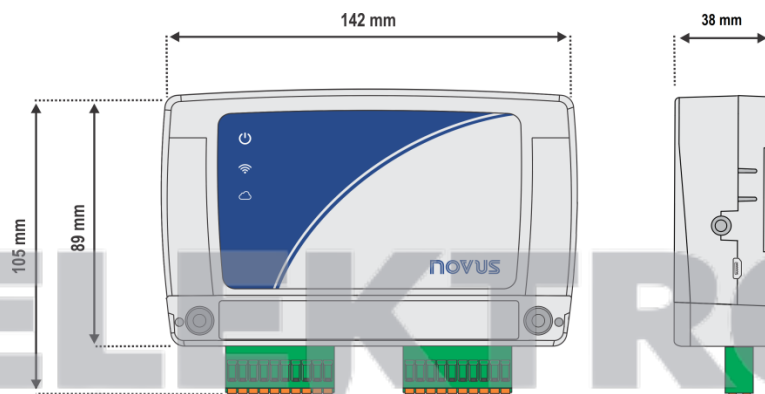

Figure 8 – Device dimensions without the protection cover

DigiRail OEE protection cover has the following dimensions:

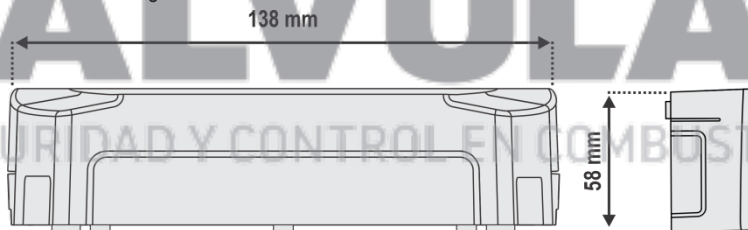

Figure 9 – Dimensions of the protection cover

4.2 ELECTRICAL INSTALLATION

DigiRail OEE has three detachable connection terminals to connect the external power supply, RS485, digital inputs and outputs and analog inputs, as shown in the figure below:

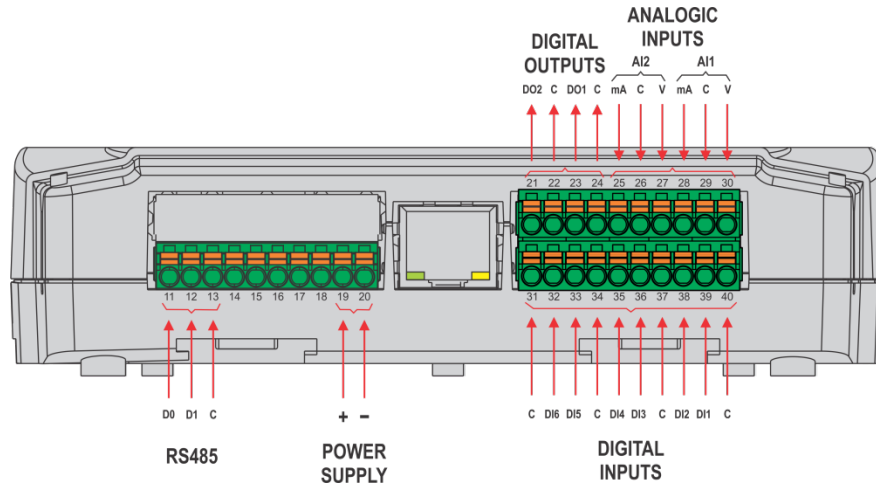

Figure 10 – Electrical connections

To connect the sensors, you must previously remove the connection terminals from the device and observe the enumeration recorded in the housing, as shown in the figure of electrical connections above.



Inputs, outputs and communication interfaces of this device are not isolated from the power supply or from each other.

INSTALLATION RECOMMENDATIONS

- Electronic and analog signal conductors must run through the plant separately from the output and power conductors. If possible, in grounded conduits.
- The power supply for the electronic instruments must come from a proper electrical grid for instrumentation.
- It is recommended to use RC FILTERS (noise suppressors) in contactor coils, solenoids, etc.
- In control applications, it is essential to consider what can happen when any part of the system fails. The device internal security features do not guarantee full protection.
- The electrical connections must be made with the device connection terminals. Before connecting them, make sure that the connections have been made properly.

4.2.1 POWER SUPPLY

The power supply connection is made at the terminals, according to the figure below. You must use a power supply with voltage between 10 and 30 V. You can also use 12 and 24 Vdc power supplies.

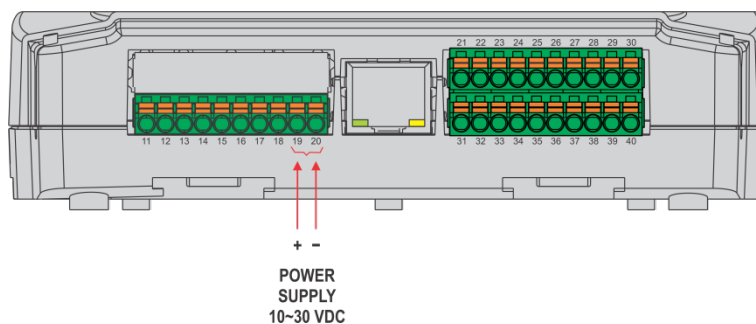

Figure 11 – Power supply

4.2.2 DIGITAL INPUT

DigiRail OEE has digital input channels that can be configured in "Counting" or "Event" modes. Regardless of the selected function, you must configure the type of sensor connected to the input: PNP, NPN or Dry Contact. After that, select the edge of the digital signal to generate the count or event: Rising edge, falling edge or both edges.

CORRELATION BETWEEN SENSOR TYPE, SENSOR STATUS AND LOGICAL LEVEL		
Sensor Type	Sensor Status	Logical Level
PNP	Open	0
	Closed	1
NPN	Open	1
	Closed	0
Dry Contact	Open	1
	Closed	0

Table 2 – Digital input

The digital input connection is made at the corresponding terminals, as shown in the figure below:

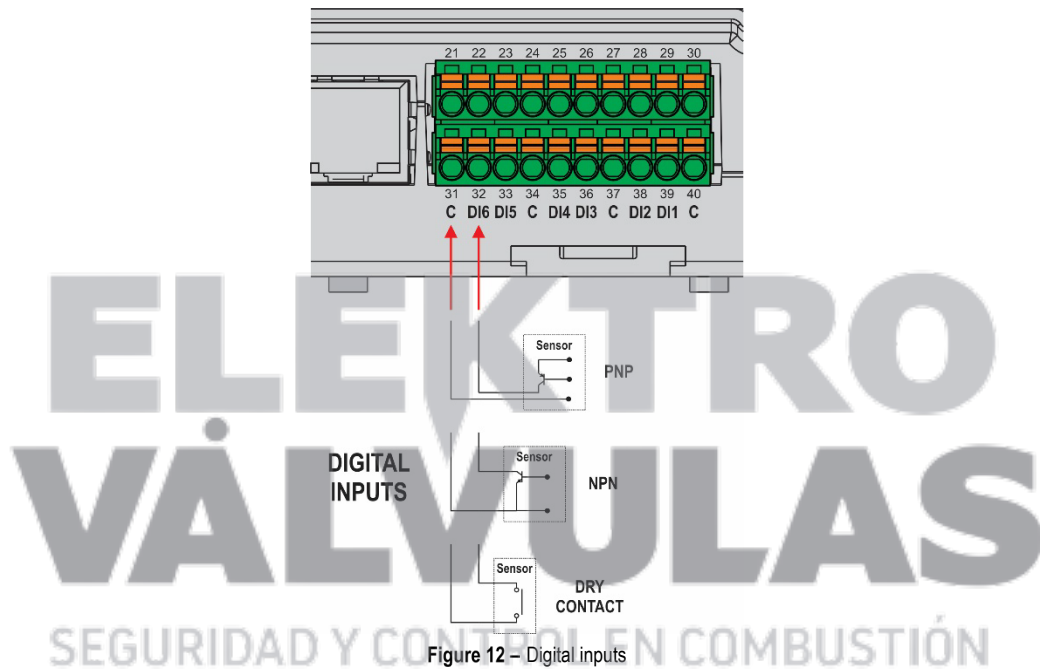

4.2.3 ANALOG INPUT

The analog input connection is made at the corresponding terminals, as shown in the figure below:

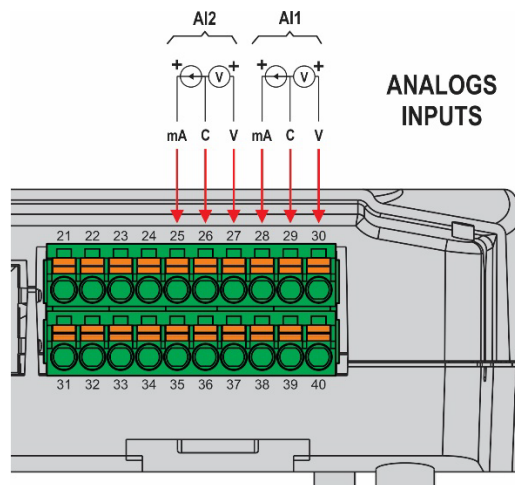

4.2.4 DIGITAL OUTPUT

The digital output connection is made at the corresponding terminals, as shown in the figure below:

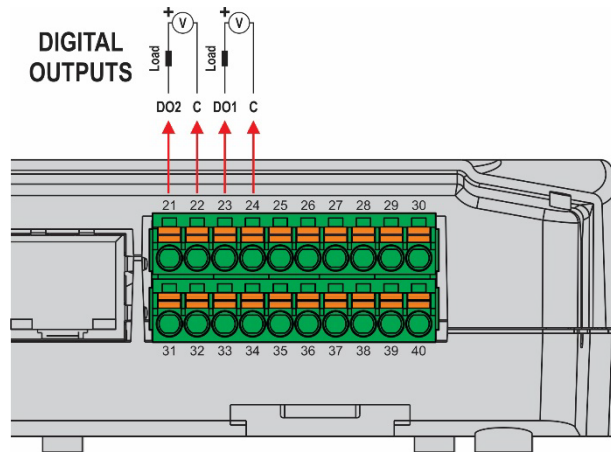

Figure 14 – Digital outputs

4.3 LED INDICATORS

DigiRail OEE has three LEDs, located on the front of the device, as shown in the figure below:

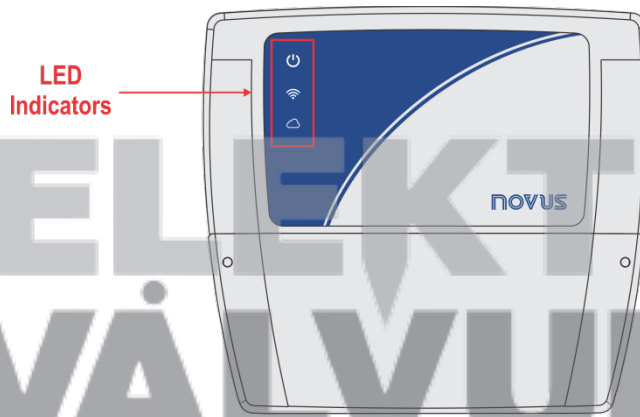

Figure 15 – LED indicators

The operation and description of each LED are as follows:



NAME	SYMBOL	STATUS	DESCRIPTION
STATUS		Off	Device off.
		On	Device on.
		Flashing	Device in firmware update mode.
WI-FI / ETHERNET CONNECTION INDICATOR		On	The connection has been established.
		Flashing	The data is being transmitted.
		Off	The connection has not been established.
MQTT BROKER CONNECTION INDICATOR		On	The connection has been established.
		Flashing	The data is being transmitted.
		Off	The connection is disabled or failed when initializing.

Table 3 – LED indicators

5 COMMUNICATION INTERFACES

5.1 USB INTERFACE

DigiRail OEE has a USB port, located on the side of the housing, to configure and perform the device C. You must use a USB cable in the standard micro-USB (not supplied) to connect the device with a desktop or notebook.

When installing the **NXperience** configuration software, the USB port drivers will be automatically installed (see chapter [CONFIGURATION SOFTWARE](#)).

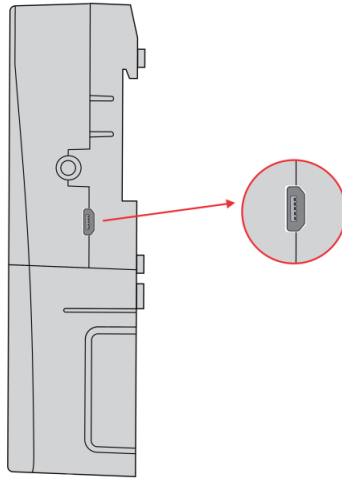

Figure 16 – USB cable connection



The USB interface is **NOT ISOLATED**.
It should be used temporarily to **CONFIGURE** or **PERFORM THE DIAGNOSIS** of the device.

5.2 RS485 INTERFACE

Operating only in Modbus-TCP Gateway mode for Modbus RTU, the RS485 connection interface is located on one of the DigiRail OEE detachable terminals, as shown in the figure below:

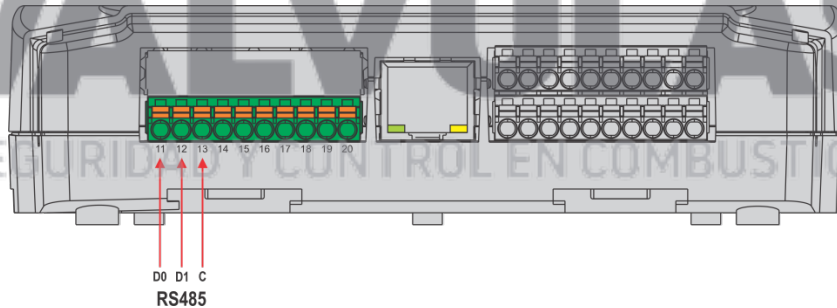

Figure 17 – RS485

The RS485 interface can be configured to operate at the following speeds (Baud Rates): 1200, 2400, 4800, 9600, 19200, 38400, 57600 and 115200. Besides, it can be configured to operate with 1 or 2 Stop Bits and in even parity, odd parity, and no parity. You can configure all these parameters using the **NXperience** software (see the [CONFIGURATION SOFTWARE](#) chapter).



The RS485 interface only works when the DigiRail OEE is connected to an external power supply. It will not operate when the device is being powered only by the USB interface.
The device has an internal 120 ohms termination resistor for the RS485 interface.

The table below shows how to connect the connectors to the RS485 communication interface:

D0	\bar{D}	D-	A	Inverted bidirectional data line.	Terminal 11
D1	D	D+	B	Bidirectional data line.	Terminal 12
C			Optional connection which improves the communication performance.	Terminal 13	
GND					

Table 4 – RS485 Connections

You can find more details about implementing a device network via RS485 in the document "RS485 and RS422 basics", available at www.novusautomation.com.

5.3 ETHERNET INTERFACE

DigiRail OEE – ETH has an Ethernet interface, located next to the device terminals, as shown in the figure below:

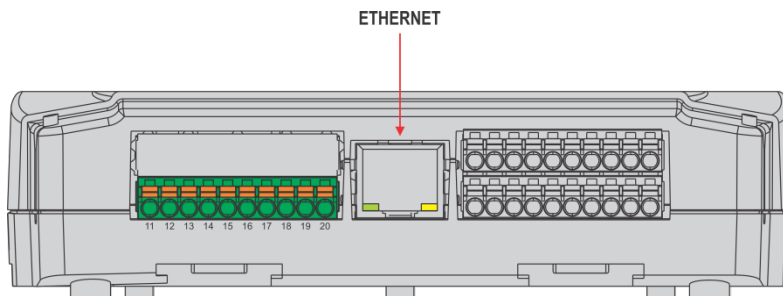



Figure 18 – Ethernet interface

If the Ethernet interface is enabled and the device is connected to an Ethernet network, the  LED on the front of the device remains on. This LED will remain on and flashing if data is being sent over this interface.

5.4 WI-FI INTERFACE

DigiRail OEE – WRL has an 802.11 Wi-Fi interface in b/g/n 2.4 GHz standards, operating through an internal antenna. This interface supports WPA-Personal (PSK) WPA/WPA2 TKIP/AES/TKIP and AES encryption.

If the Wi-Fi interface is enabled and the device is connected to a Wi-Fi network, the  LED on the front of the device remains on. This LED will remain on and flashing if data is being sent over this interface.

**ELEKTRO
VÁLVULAS**
SEGURIDAD Y CONTROL EN COMBUSTIÓN

DigiRail OEE is compatible with Message Queue Telemetry Transport (MQTT) protocol, which allows publishing data in the cloud, and supports the following MQTT Brokers: Google Cloud, Microsoft Azure, AWS, **NOVUS Cloud**, LiveMES, Mina and generic MQTT Brokers.

This chapter describes the structure of the data published in the cloud and introduces the structure to send settings to the device.

6.1 PUBLICATION AND SUBSCRIPTION TOPICS

As described below, DigiRail OEE uses five topics for operation:

- **Topic to publish periodic data and events:** Used to publish data generated on the device, i.e., the logs. There are two types: **channel** and **events**.
- **Topic to receive the configuration:** Used to receive configuration data. The device subscribes to this topic to receive configuration data. For each configuration received, a confirmation reply is published in the configuration confirmation topic.
- **Topic to confirm the configuration:** The device publishes the current configuration in this topic. Every time a configuration is received, the device publishes a confirmation in this topic. After a configuration is applied to the device, the current configuration is also published in this topic.
- **Topic to receive commands:** Used to receive commands. The device subscribes to this topic to receive commands and signals the execution of a command by publishing in the command confirmation topic.
- **Topic to confirm the command:** The device publishes the result of commands executed in this topic.

Examples of topics for a generic Broker:

TOPIC	USE
Topic to publish periodic data and events	NOVUS/device1/events
Topic to receive the configuration	NOVUS/device1/config
Topic to confirm the configuration	NOVUS/device1/ack/config
Topic to receive commands	NOVUS/device1/command
Topic to confirm commands	NOVUS/device1/ack/command

Table 5 – Topics for a generic Broker

6.2 PUBLISH BASIC MODEL

To simplify the treatment of MQTT message content, publications will always display the product model identifier and the user-defined identifier, labeled by the "pid" and "device_id" fields, respectively. The value of the "device_id" field is set in the Device ID parameter of the MQTT settings of the NXperience software.

Applicable DigiRail OEE Identifiers:

MODEL	PID
DigiRail OEE ETH	51452945
DigiRail OEE WRL	51387408

Table 6 – Identifiers

6.3 TRANSMISSION MODEL FOR DATA AND EVENTS

The publication of events and data generated by the device follows the standard MQTT model and uses a topic defined during configuration.

6.2.1 DATA AND EVENTS

The data will be published in the topic defined for the publication of periodic data and events. The type of data is indicated in the JSON message. For all data, the timestamps used are in Unix timestamp UTC format (GMT 0).

6.2.2 CHANNEL DATA

The channel data is published periodically, according to the device configuration. The data is in JSON format and has the following key/value sets:

```
{
  "pid": 51387408,
  "device_id": "device0",
  "channels" : {
    "timestamp":1585819219,
    "chd1_value":0,
    "chd2_value":0,
    "chd3_value":0,
    "chd4_value":0,
    "chd5_value":0,
    "chd6_value":0,
    "ch1_user_range":2,
    "ch2_user_range":-19991
  }
}
```

```
}
}
```

Notes:

- The **timestamp** value is the timestamp in Unix UTC format at the time the device reads the channel.
- **chdX_value** corresponds to the information of the digital channels at the time of timestamp. If the channel is not enabled, it will not appear in the JSON. If the channel is in "Register" mode, the value will correspond to the logical level of the digital channel at that moment. If the channel is in "Counting" mode, the value will correspond to the counter value at that time.
- **chX_user_range** informs the value of the analog input in the range configured by the user and at the time of the timestamp. If the analog channel is not enabled, it will not appear in the JSON.

6.2.3 EVENTS

When the digital channel is configured in "Event" mode and an event occurs, an event type message will be generated, indicating the channel, the timestamp, and the edge where it occurred. The data are in JSON format and have the following key/value sets:

```
{
  "pid": 51387408,
  "device_id": "device0",
  "events": {
    "chd1": {
      "timestamp":1585819219.685,
      "edge":1,
    }
  }
}
```

Notes:

- The **timestamp** value is also in Unix timestamp format in UTC (GMT 0), but the milliseconds of the event have been added as fractional part.
- Regarding the **edge** value: "1" means that the event occurred on a rising edge. "0" means that the event occurred on a falling edge.

6.4 CONFIGURATION

Some sets of device configuration can be changed or consulted via MQTT when publishing in the topic to receive device configuration. A confirmation of this publication is received in the configuration confirmation topic.

The available configuration items for this device type are:

CONFIGURATION ITEM	DESCRIPTION
rtc	RTC (Real Time Clock - device internal clock) configuration.
device	General device configuration.
chdX	Digital channel 'X' configuration (Available: chd1 , chd2 , chd3 , chd4 , chd5 and chd6).
Periodic counter reset	Configuration of the digital counters reset periodicity.
chX	Configuration of the analog channel 'X' (Available: ch1 and ch2).
eth	Network configuration parameters.
wifi	Wi-Fi interface configuration (When available).
ntp	NTP server configuration for automatic clock adjust.
modbus-tcp	Modbus-TCP protocol configuration.
rs485	RS485 interface configuration.

Table 7 – Configuration item

6.3.1 TRANSMISSION MODEL FOR CONFIGURATIONS AND COMMANDS

The basic operating model of the commands and configurations was developed to allow synchronization of the device settings and conditions with the cloud.

In this model there are two basic concepts:

- **Desired properties:** These are the conditions and configurations that the backend application can change or query on the device with which it interacts.
- **Reported properties:** These are the properties used as a response to receive **Desired properties**, where the device reports its status or the result of a command.

This message exchange model needs two different topics to work. The first is the topic in which the device is subscribed to receive the **Desired properties**. This step, initiated by the application, is called "**request**". The device uses the second topic to publish the **Reported properties** after the command or configuration is executed. This step is called "**response**".

For details on sending configurations via MQTT to **DigiRail OEE**, you should refer to the MQTT Protocol document available on the product page on **NOVUS** website.

6.5 COMMANDS

Following the same model of sending settings, the commands must be published in the **Topic to receive commands**. The type of data is indicated in the JSON message. The return of the command execution is done through the **Topic to confirm the command**.

The available commands for **DigiRail OEE** are:

- **Output:** Used to obtain or modify the digital outputs status.
- **Reset counters:** Used to apply a reset to the digital counters.
- **Set Counters:** Used to change the value of the digital channel counters.
- **Get diagnostic:** Used to obtain diagnostic data from the device.

6.4.1 OUTPUT

This command modifies the device output status.

FORMAT OF THE OUTPUT COMMAND TO MODIFY THE OUTPUT STATUS:

```
{
  "timestamp":1585819219,
  "desired": {
    "output": {
      "out1":1,
      "out2":1
    }
  }
}
```

It is not necessary to publish the status that will not be modified.

FORMAT OF THE COMMAND OUTPUT RESPONSE:

```
{
  "pid": 51387408,
  "device_id": "device0",
  "timestamp":1585819219,
  "reported": {
    "output": {
      "error": 0,
      "out1":1,
      "out2":1
    }
  }
}
```

Notes:

- The **timestamp** is the same as the command received (**desired**).
- The status described in the **desired** step will only be applied if the execution is done without errors.
- The value shown in the **error** field is an integer and reports the first error found in the execution of the command, as shown in the error codes table below:

CODE	DESCRIPTION
Error 0	Success.
Error 1	The structure is correct, but the device has received an out-of-range parameter.
Error 2	The structure is correct, but the device has received an unknown parameter.

Table 8 – Error codes

There are, however, unanswered error cases from the device, as shown below:

- The JSON structure is wrong.
- The structure is right, but some element is missing (**timestamp, desired, item**).

In case of error, none of the parameters will be accepted and the device will not go into configuration mode.

- If the command has failed, the status indicated in **reported** will be the current ones.

This command can also be used to consult the status of the device outputs when sent with the format provided below.

FORMAT OF THE *OUTPUT* COMMAND TO OBTAIN THE OUTPUT STATUS:

```
{
  "timestamp":1585819219,
  "desired": {
    "output": {}
  }
}
```

THE FORMAT OF THE RESPONSE TO OBTAIN THE OUTPUT STATUS IS THE SAME FORMAT AS THE RESPONSE TO THE COMMAND TO MODIFY THEM:

```
{
  "pid": 51387408,
  "device_id": "device0",
  "timestamp":1585819219,
  "reported": {
    "output": {
      "error": 0,
      "out1":1,
      "out2":1
    }
  }
}
```

6.4.2 RESET COUNTERS

The **reset counters** command is used so that the application can reset the digital channels counters. A digital channel needs to have MQTT enabled for it to be restarted through this interface.

The structure used for this command follows the same model as for sending configurations, using the concepts of **desired** and **reported**.

The **reset_chdX** value can assume values of 0 or 1. The value of "1" indicates that a reset is to be applied to the counter of the corresponding digital channel. The value "0" indicates that the counter should not be changed. In this case, it is also possible to simply omit the JSON channel.

REQUEST *RESET COUNTERS*:

```
{
  "timestamp":1585819219,
  "desired": {
    "reset_counters" : {
      "reset_chd2":1,
      "reset_chd4":1
    }
  }
}
```

RESPONSE *RESET COUNTERS*:

```
{
  "pid": 51387408,
  "device_id": "device0",
  "timestamp":1585819219,
  "reported" : {
    "reset_counters": {
      "error": 0,
      "reset_chd1":0,
      "reset_chd2":0,
      "reset_chd3":0,
      "reset_chd4":0,
      "reset_chd5":0,
      "reset_chd6":0
    }
  }
}
```

Notes:

- The **timestamp** is the same as the command received (**desired**).
- The status described in the **desired** step will only be applied if the execution is done without errors.
- The **error** value is an integer and reports the error found during the command execution.
- In this example, digital channels 1, 3, 5 and 6 do not appear in the JSON **desired** since you do not want to reset their counters.

6.4.3 SET COUNTERS

The **set_counters** command is used so that the application can change the value of the digital channel counters. You must enable the permission to change the configuration through MQTT to modify a digital channel through this interface.

The structure of this command follows the same model as for sending settings, using the "**desired**" and "**reported**" concepts.

The **set_chdX** can assume any value between 0 and X. If the setting allows it, the channel will immediately assume the defined value when sending the value on the **set_chdX** field. You must omit the channel from the JSON in order not to change the counter value of a channel.

REQUEST SET COUNTERS:

```
{
  "timestamp":1620413979
  "desired": {
    "set_counters" : {
      "set_chd2":6500,
      "set_chd3":10
    }
  }
}
```

RESPONSE SET COUNTERS:

```
{
  "pid": 51387408,
  "device_id": "device0",
  "timestamp":1620413979,
  "reported" : {
    "set_counters": {
      "error": 0,
      "set_chd1":0,
      "set_chd2":6500,
      "set_chd3":10,
      "set_chd4":0,
      "set_chd5":0,
      "set_chd6":0
    }
  }
}
```

Notes:

- The **timestamp** is the same as the command received (**desired**).
- The status described in the **desired** step will only be applied if the execution is done without errors.
- The **error** value is an integer and reports the error found during the command execution.
- In this example, digital channels 1, 4, 5 and 6 do not appear in the JSON **desired** since you do not want to change their counters. In the response, the current value of the digital channel will be returned. For digital channels 1, 4, 5 and 6 the current value is assumed to be zero.

6.4.4 GET DIAGNOSTIC

The `get diagnostic` command returns diagnostic data from the device.

REQUEST GET DIAGNOSTIC:

```
{
  "timestamp":1585819219,
  "desired" : {
    "diag" : {}
  }
}
```

RESPONSE GET DIAGNOSTIC:

```
{
  "pid": 51387408,
  "device_id": "device0",
  "timestamp":1585819219,
  "reported" : {
    "diag": {
      "title": "Pci v2",
      "location":"home",
      "curr_timestamp":1589326517,
      "cfg_timestamp":1589311676,
      "fw_v":"1.23",
      "mqtt_queue":1,
      "sn":"00000001",
      "curr_rssi":"55",
      "min_rssi":"46",
      "max_rssi":"87",
      "avg_rssi":"54",
      "ipv4":[ 192, 168, 0, 23 ]
    }
  }
}
```

If the **Publish Diagnostics Periodically** parameter of the **NXperience** configuration software (see the [MQTT PROTOCOL](#) section of the [CONFIGURATION SOFTWARE](#) chapter) is enabled, the system event occurrence counters will also be added to the response:

```
{
  "pid_id":51387408,
  "device_id":"device0",
  "timestamp":1585819219,
  "reported":{
    "diag":{
      "error":0,
      "title":"Pci v2",
      "location":" home ",
      "curr_timestamp":1589326517,
      "cfg_timestamp":1589311676,
      "fw_v":"1.23",
      "mqtt_queue":1,
      "sn":"00000001",
      "curr_rssi":"55",
      "min_rssi":"45",
      "max_rssi":"70",
      "avg_rssi":"55",
      "ipv4":[
        192,
        168,
        0,
        23
      ],
      "log_counters":{
        "pwr_on":1,

```

6.4.5 GATEWAY MQTT RS485

Sending packets through the RS485 serial interface via MQTT allows you to read data from a local network (Modbus RTU, for example) and send commands remotely via the MQTT protocol. In this case, **DigiRail OEE** operates as a Gateway, communicating with the slave devices through the RS485 serial interface.

To send commands remotely, it is necessary to connect another MQTT client to the Broker to which **DigiRail OEE** is connected and, in the sequence, register in the topic configured for command confirmation. The command must then be published in the topic configured in **DigiRail OEE** to receive commands.

Modbus RTU commands can be published in hexadecimal format with the following structure:

```
{
  "timestamp":XXXXXX,
  "desired": {
    "gateway_485": {"mb_buffer":"bytes in hexadecimal to transmit through serial 485"}
  }
}
```

Below is an example of a message to be published in the command sending topic:

```
{
  "timestamp":15,
  "desired": {
    "gateway_485": {"mb_buffer":"02 03 00 00 00 0A C5 FE"}
  }
}
```

In sequence, the response received through the RS485 serial interface will be published by **DigiRail OEE** in the topic assigned to the commands confirmation, following the format:

```
{
  "pid": XXX,
  "device_id":XX,
  "timestamp":XXXX,
  "reported": {
    "gateway_485": {"error":0; "mb_buffer":"bytes received in response to the command sent"}
  }
}
```

An example message that could be received in the command confirmation topic:

```
{
  "pid": 51387408,
  "device_id":"DeviceName",
  "timestamp":15,
  "reported": {
    "gateway_485": {"error":0; "mb_buffer":"00 03 14 19 C7 00 00 06 4E 00 00 04 E0 00 00 03 D
0 00 00 03 D0 00 00 1B 13"}
  }
}
```

6.4.6 RESET DIAGNOSTIC

The `reset diagnostic` command is used so that the application can reset counters related to internal system events and Wi-Fi signal quality (RSSI) measurement data.

The structure used for this command follows the same model as for sending configurations and uses the concepts of `desired` and `reported`.

The values of the `reset_watchdog_counter`, `reset_x_counter` and `reset_diag_rssi` fields can have values of 0 or 1. The value "1" means that a reset is to be applied to the corresponding parameter. The value "0" indicates that the parameter should not be changed. In this case you can also simply omit the JSON channel.

REQUEST RESET DIAGNOSTIC:

```
{
  "timestamp":1585819219,
  "desired": {
    "reset_diag": {
      "reset_watchdog_counter":0,
      "reset_logs_counter":1,
      "reset_diag_rssi":1
    }
  }
}
```

RESPONSE RESET DIAGNOSTIC:

```
{
  "pid": 51387408,
  "device_id": "device0",
  "timestamp":1585819219,
  "reported": {
    "reset_diag": {
      "error": 0,
      "reset_watchdog_counter":0,
      "reset_logs_counter":0,
      "reset_diag_rssi":0
    }
  }
}
```

Notes:

- The `timestamp` is the same as the received command (`desired`).
- The status described in `desired` will only be applied if execution is done without errors.
- The value of `error` is an integer and reports the error encountered during the execution of the command.

6.4.7 LOGS

The logs command returns the last 50 log events from the system. All events will have an ID, which can be queried with this command, and a timestamp of the occurrence. You can see a detailed description of the log in [Table 8](#).

REQUEST LOGS:

```
{
  "timestamp":1585819219,
  "desired": {
    "logs": {}
  }
}
```

RESPONSE LOGS:

```
{
  "pid":51387408,
  "device_id":"droee",
  "timestamp":1585819219,
  "reported":{
    "logs":{
      "error":0,
      "events":[
        {
          "ts":1638193059,
```

The table below shows a detailed description of the logs:

CODE	LOGS_PARSED		DESCRIPTION
0	pwr	on	Standard startup.
1	pwr	sw_reset	Startup triggered by software reset.
2	pwr	wdt_reset	Startup triggered by internal Watchdog.
3	pwr	lvd_reset	Startup triggered by power outage.
4	net	connected	Connected to a network (Wi-Fi or Ethernet).
5	net	disconnected	Disconnected from the network (Wi-Fi or Ethernet).
6	wifi	prov_error	Wi-Fi provisioning failure (SSID or password incorrect).
7	dhcp	error	DHCP error.
8	sntp	error	SNTP error.
9	mqtt	connected	Connected to a MQTT broker.
10	mqtt	disconnected	Disconnected from the MQTT broker.
11	mqtt	sub_error	MQTT topics subscription error.
12	mqtt	pub_error	MQTT topics publishing error.
13	mqtt	alter_int	Publish interval has been changed to an alternative interval.
14	mqtt	default_int	Publish interval has been changed to a default interval.
15	dns	error_1	DNS internal error - Phase 1.
16	dns	error_2	DNS internal error - Phase 2.
17	dns	error_3	DNS internal error - Phase 3.
18	mem	init_error	There was an error during the circular buffer initialization. Device has recovered.
19	mem	not_init	The circular buffer has not been initialized.
20	mem	read_error	There was a failure while reading the circular buffer.
21	cfg	updated	Device configuration updated.
22	fw	updated	Device firmware updated.

Table 9 – Detailed log description

7 MODBUS-TCP PROTOCOL

DigiRail OEE is compatible with the Modbus-TCP protocol, a data communication protocol used to connect the device to supervisory control and data acquisition (SCADA) systems. It supports up to 3 simultaneous connections and allows up to 3 Modbus-TCP clients (masters) to monitor it at the same time. DigiRail OEE operates both as a Modbus-TCP server (slave) and as a TCP/RTU gateway.

As a server (slave), it responds to the configured Modbus RTU address. For address that diverge from the configured address value, it will operate as a TCP/RTU gateway. In this case, the packed will be sent to the RS485 interface and, if there is a reply from any Modbus RTU slave, replied to the Modbus-RTU client (master) that generated the request.

For more information about Modbus-TCP protocol, you should refer to the Modbus-TCP Protocol document available on the product page on NOVUS website.

7.1 COMMANDS

READ HOLDING REGISTERS – 0x03:

This command can be used to read the value of one or up to a maximum of 125 consecutive registers, according to the table below.

WRITE HOLDING REGISTERS – 0x06:

This command can be used to write in a register, according to the table below.

WRITE MULTIPLE HOLDING REGISTERS – 0x16:

This command can be used to write in multiple registers, according to the table below.

7.2 REGISTERS TABLE

Below is the table of registers supported by the device:

ADDRESS	REGISTER	DESCRIPTION	MINIMUM VALUE	MAXIMUM VALUE	TYPE
1	HR_PRODUCT_CODE	Product code.	510	510	RO
2	HR_SERIAL_NUMBER_H	Serial number (32bits).	0x0000	0xFFFF	RO
3	HR_SERIAL_NUMBER_L		0x0000	0xFFFF	RO
4	HR_FIRMWARE_VERSION	Version firmware x 100.	100	65535	RO
		Reserved.			
6	HR_MAC_ADDR_0_1	MAC Address. Hexadecimal format with 2 numbers per register. 0 : 1 : 2 : 3 : 4 : 5	0x0000	0xFFFF	RO
7	HR_MAC_ADDR_2_3		0x0000	0xFFFF	RO
8	HR_MAC_ADDR_4_5		0x0000	0xFFFF	RO
		Reserved.			
10	HR_USB_STATUS	USB interface status: 0 → Disconnected 1 → Connected	0	1	RO
		Reserved.			
13	HR_NUMBER_OF_ACTIVE_CH	Number of enabled analog channels.	0	6	RO
14	HR_NUMBER_OF_ACTIVE_CHD	Number of enabled digital channels.	0	6	RO
15	HR_RESET_COUNTERS	Reset of digital channel counters. Note: Write 1 resets all the digital counters that are configured to be reset by Modbus-TCP and MQTT.	0	1	RW
16	HR_PWR_STATUS	Power supply status: 0 → Powered by the USB interface 1 → Powered by external supply	1	1	RO
17	HR_STATUS_OF_RECORDS	Number of registers pending submission via MQTT protocol.	0	65535	RO
		Reserved.			
20	HR_LAST_CONFIG_YEAR,	Year of the last configuration.	2016	2080	RO
21	HR_LAST_CONFIG_MONTH,	Month of the last configuration.	1	12	RO
22	HR_LAST_CONFIG_DAY,	Day of the last configuration.	1	31	RO
23	HR_LAST_CONFIG_HOUR,	Hour of the last configuration.	0	23	RO
24	HR_LAST_CONFIG_MINUTE,	Minute of the last configuration.	0	59	RO
25	HR_LAST_CONFIG_SECOND	Second of the last configuration.	0	59	RO
26	HR_CURRENT_YEAR	Current year.	2016	2080	RO
27	HR_CURRENT_MONTH	Current month.	1	12	RO

ADDRESS	REGISTER	DESCRIPTION	MINIMUM VALUE	MAXIMUM VALUE	TYPE
28	HR_CURRENT_DAY	Current day.	1	31	RO
29	HR_CURRENT_HOUR	Current hour.	0	23	RO
30	HR_CURRENT_MINUTE	Current minute.	0	59	RO
31	HR_CURRENT_SECOND	Current second.	0	59	RO
		Reserved.			
34	HR_RESET_COUNTER_CHD1	Resets the digital channel counter 1. Note: Write 1 resets the counter for this channel if it is configured to allow reset via Modbus-TCP and MQTT protocols.	0	1	RW
35	HR_RESET_COUNTER_CHD2	Resets the digital channel counter 2. Note: Write 1 resets the counter for this channel if it is configured to allow reset via Modbus-TCP and MQTT protocols.	0	1	RW
36	HR_RESET_COUNTER_CHD3	Resets the digital channel counter 3. Note: Write 1 resets the counter for this channel if it is configured to allow reset via Modbus-TCP and MQTT protocols.	0	1	RW
37	HR_RESET_COUNTER_CHD4	Resets the digital channel counter 4. Note: Write 1 resets the counter for this channel if it is configured to allow reset via Modbus-TCP and MQTT protocols.	0	1	RW
38	HR_RESET_COUNTER_CHD5	Resets the digital channel counter 5. Note: Write 1 resets the counter for this channel if it is configured to allow reset via Modbus-TCP and MQTT protocols.	0	1	RW
39	HR_RESET_COUNTER_CHD6	Resets the digital channel counter 6. Note: Write 1 resets the counter for this channel if it is configured to allow reset via Modbus-TCP and MQTT protocols.	0	1	RW
		Reserved.			
41	HR_DIGITAL_OUT1_VALUE	Digital output status and control: 0 → OFF 1 → ON Allows you to read and write to the output.	0	1	RW
42	HR_DIGITAL_OUT2_VALUE	Digital output status and control: 0 → OFF 1 → ON Allows you to read and write to the output.	0	1	RW
		Reserved.			
45	HR_CHD1_STATUS	Digital channel status: 0 → Not configured 1 → OK 2 → The configuration has an error	0	2	RO
46	HR_CHD1_VALUE_HIGH	Counter value in 32-bit.	0	65535	RO
47	HR_CHD1_VALUE_LOW		0	65535	RO
48	HR_CHD1_TIME_STAMP_LAST_HIGH	Last event timestamp. 32-bit. Unix format.	0x0000	0xFFFF	RO
49	HR_CHD1_TIME_STAMP_LAST_LOW		0x0000	0xFFFF	RO
		Reserved.			
56	HR_CHD2_STATUS	Digital channel status: 0 → Not configured 1 → OK 2 → The configuration has an error	0	2	RO
57	HR_CHD2_VALUE_HIGH	Counter value in 32-bit.	0	65535	RO
58	HR_CHD2_VALUE_LOW		0	65535	RO
59	HR_CHD2_TIME_STAMP_LAST_HIGH	Last event timestamp. 32-bit. Unix format.	0x0000	0xFFFF	RO
60	HR_CHD2_TIME_STAMP_LAST_LOW		0x0000	0xFFFF	RO
		Reserved.			
67	HR_CHD3_STATUS	Digital channel status:	0	2	RO

ADDRESS	REGISTER	DESCRIPTION	MINIMUM VALUE	MAXIMUM VALUE	TYPE
		0 → Not configured 1 → OK 2 → The configuration has an error			
68	HR_CHD3_VALUE_HIGH	Counter value in 32-bit.	0	65535	RO
69	HR_CHD3_VALUE_LOW		0	65535	RO
70	HR_CHD3_TIME_STAMP_LAST_HIGH	Last event timestamp. 32-bit. Unix format.	0x0000	0xFFFF	RO
71	HR_CHD3_TIME_STAMP_LAST_LOW		0x0000	0xFFFF	RO
		Reserved.			
78	HR_CHD4_STATUS	Digital channel status: 0 → Not configured 1 → OK 2 → The configuration has an error	0	2	RO
79	HR_CHD4_VALUE_HIGH	Counter value in 32-bit.	0	65535	RO
80	HR_CHD4_VALUE_LOW		0	65535	RO
81	HR_CHD4_TIME_STAMP_LAST_HIGH	Last event timestamp. 32-bit. Unix format.	0x0000	0xFFFF	RO
82	HR_CHD4_TIME_STAMP_LAST_LOW		0x0000	0xFFFF	RO
		Reserved.			
89	HR_CHD5_STATUS	Digital channel status: 0 → Not configured 1 → OK 2 → The configuration has an error	0	2	RO
90	HR_CHD5_VALUE_HIGH	Counter value in 32-bit.	0	65535	RO
91	HR_CHD5_VALUE_LOW		0	65535	RO
92	HR_CHD5_TIME_STAMP_LAST_HIGH	Last event timestamp. 32-bit. Unix format.	0x0000	0xFFFF	RO
93	HR_CHD5_TIME_STAMP_LAST_LOW		0x0000	0xFFFF	RO
		Reserved.			
100	HR_CHD6_STATUS	Digital channel status: 0 → Not configured 1 → OK 2 → The configuration has an error	0	2	RO
101	HR_CHD6_VALUE_HIGH	Counter value in 32-bit.	0	65535	RO
102	HR_CHD6_VALUE_LOW		0	65535	RO
103	HR_CHD6_TIME_STAMP_LAST_HIGH	Last event timestamp. 32-bit. Unix format.	0x0000	0xFFFF	RO
104	HR_CHD6_TIME_STAMP_LAST_LOW		0x0000	0xFFFF	RO
		Reserved.			
109	HR_CH1_STATUS	Analog channel 1 status: 0 → Not configured 1 → OK 2 → The configuration has an error	0	2	RO
		Reserved.			
111	HR_CH1_MV_MA_VALUE_H	Value in the unit of measurement (mA or V). Float 32-bit format.	0x0000	0xFFFF	RO
112	HR_CH1_MV_MA_VALUE_L		0x0000	0xFFFF	RO
113	HR_CH1_SENSE_USER_RANGE_H	Value in user range. Float 32-bit format. Note: This is the same value as the cloud publication.	0x0000	0xFFFF	RO
114	HR_CH1_SENSE_USER_RANGE_L		0x0000	0xFFFF	RO
120	HR_CH2_STATUS	Analog channel 2 status: 0 → Not configured 1 → OK 2 → The configuration has an error	0	2	RO
		Reserved.			
122	HR_CH2_MV_MA_VALUE_H	Value in the unit of measurement (mA or V). Float 32-bit format.	0x0000	0xFFFF	RO
123	HR_CH2_MV_MA_VALUE_L		0x0000	0xFFFF	RO
124	HR_CH2_SENSE_USER_RANGE_H	Value in user range. Float 32-bit format.	0x0000	0xFFFF	RO

ADDRESS	REGISTER	DESCRIPTION	MINIMUM VALUE	MAXIMUM VALUE	TYPE
125	HR_CH2_SENSE_USER_RANGE_L	Note: This is the same value as the cloud publication.	0x0000	0xFFFF	RO
		Reserved.			
130	HR_MQTT_LAST_UPDATE_YEAR	Year of last sending to the MQTT Broker.	1	1	RO
131	HR_MQTT_LAST_UPDATE_MONTH	Month of the last sending to the MQTT Broker.	1	12	RO
132	HR_MQTT_LAST_UPDATE_DAY	Day of the last sending to the MQTT Broker.	1	31	RO
133	HR_MQTT_LAST_UPDATE_HOUR	Time of the last sending to the MQTT Broker.	0	23	RO
134	HR_MQTT_LAST_UPDATE_MINUTE	Minute of the last sending to the MQTT Broker.	0	59	RO
135	HR_MQTT_LAST_UPDATE_SECOND	Second of the last sending to the MQTT Broker.	0	59	RO
136	HR_MQTT_STATUS_BROKER	Communication status with the MQTT Broker: 0 → Broker disconnected 1 → Broker connected 2 → DNS problem 3 → Broker error 4 → Connecting to the Broker	0	4	RO
		Reserved.			
139	HR_WIFI_RSSI	Signal quality between the device and the Wi-Fi Gateway displayed in percent. The higher the value, the better the signal.	0	65535	RO
		Reserved.			
141	HR_LAN_GATEWAY_COM_STATUS	ETH communication status: 0 → Gateway disconnected 1 → Gateway connected 2 → Wi-Fi provisioning error 3 → Obtaining IP via DHCP 4 → Error obtaining IP via DHCP	0	4	RO
142	HR_LAN_IP_ADDR_0_1	IPv4 address. Two octets per register.	0	65535	RO
143	HR_LAN_IP_ADDR_2_3	Dec 0 . Dec 1 . Dec 2 . Dec 3	0	65535	RO
144	HR_LAN_MASK_ADDR_0_1	Mask. Two octets per register.	0	65535	RO
145	HR_LAN_MASK_ADDR_2_3	Dec 0 . Dec 1 . Dec 2 . Dec 3	0	65535	RO
146	HR_LAN_GATEWAY_ADDR_0_1	Gateway. Two octets per register.	0	65535	RO
147	HR_LAN_GATEWAY_ADDR_2_3	Dec 0 . Dec 1 . Dec 2 . Dec 3	0	65535	RO
148	HR_LAN_DNS_ADDR_0_1	DNS server IP. Two octets per register.	0	65535	RO
149	HR_LAN_DNS_ADDR_2_3	Dec 0 . Dec 1 . Dec 2 . Dec 3	0	65535	RO
		Reserved.			
151	HR_LAN_IPV6_ADDR_0_1,	IPv6 address – Local. Hexadecimal format. 0_1 : 2_3 : 4_5 : 6_7 : 8_9 : 10_11 : 12_13 : 14_15	0	65535	RO
152	HR_LAN_IPV6_ADDR_2_3,		0	65535	RO
153	HR_LAN_IPV6_ADDR_4_5,		0	65535	RO
154	HR_LAN_IPV6_ADDR_6_7,		0	65535	RO
155	HR_LAN_IPV6_ADDR_8_9,		0	65535	RO
156	HR_LAN_IPV6_ADDR_10_11,		0	65535	RO
157	HR_LAN_IPV6_ADDR_12_13,		0	65535	RO
158	HR_LAN_IPV6_ADDR_14_15,		0	65535	RO
159	HR_LAN_IPV6_GLOBAL_ADDR_0_1,	IPv6 address – Global. Hexadecimal format. 0_1 : 2_3 : 4_5 : 6_7 : 8_9 : 10_11 : 12_13 : 14_15	0	65535	RO
160	HR_LAN_IPV6_GLOBAL_ADDR_2_3,		0	65535	RO
161	HR_LAN_IPV6_GLOBAL_ADDR_4_5,		0	65535	RO
162	HR_LAN_IPV6_GLOBAL_ADDR_6_7,		0	65535	RO
163	HR_LAN_IPV6_GLOBAL_ADDR_8_9,		0	65535	RO
164	HR_LAN_IPV6_GLOBAL_ADDR_10_11,		0	65535	RO
165	HR_LAN_IPV6_GLOBAL_ADDR_12_13,		0	65535	RO
166	HR_LAN_IPV6_GLOBAL_ADDR_14_15,		0	65535	RO
167	HR_CHD1_LEVEL,	Logical level of digital input 1.	0	1	RO
168	HR_CHD2_LEVEL,	Logical level of digital input 2.	0	1	RO

ADDRESS	REGISTER	DESCRIPTION	MINIMUM VALUE	MAXIMUM VALUE	TYPE
169	HR_CHD3_LEVEL,	Logical level of digital input 3.	0	1	RO
170	HR_CHD4_LEVEL,	Logical level of digital input 4.	0	1	RO
171	HR_CHD5_LEVEL,	Logical level of digital input 5.	0	1	RO
172	HR_CHD6_LEVEL,	Logical level of digital input 6.	0	1	RO
173		Reserved.			
174	HR_CHD1_SETVALUE_H	Changes the value of the 32-bit counter for channel 1.	0	65535	RW
175	HR_CHD1_SETVALUE_L		0	65535	RW
176	HR_CHD2_SETVALUE_H	Changes the value of the 32-bit counter for channel 2.	0	65535	RW
177	HR_CHD2_SETVALUE_L		0	65535	RW
178	HR_CHD3_SETVALUE_H	Changes the value of the 32-bit counter for channel 3.	0	65535	RW
179	HR_CHD3_SETVALUE_L		0	65535	RW
180	HR_CHD4_SETVALUE_H	Changes the value of the 32-bit counter for channel 4.	0	65535	RW
181	HR_CHD4_SETVALUE_L,		0	65535	RW
182	HR_CHD5_SETVALUE_H	Changes the value of the 32-bit counter for channel 5.	0	65535	RW
183	HR_CHD5_SETVALUE_L		0	65535	RW
184	HR_CHD6_SETVALUE_H	Changes the value of the 32-bit counter for channel 6.	0	65535	RW
185	HR_CHD6_SETVALUE_L		0	65535	RW
186		Reserved.			
187	HR_SS_COLLECT_RECORD_MAX_QTTY	Maximum number of downloads supported by memory.	1824	7096	RO
188	HR_SS_COLLECT_LAST_RECORD	Position of the last download added to memory.	0	7096	RO
189	HR_SS_COLLECT_FIRST_RECORD	Position of the first download added to memory.	0	7096	RO
190	HR_SS_COLLECT_REQUESTED_RECORD	Position of the download requested for reading.	0	7096	RW
191	HR_SS_COLLECT_TIMESTAMP_UNIX_H	Timestamp of the requested download in Unix format.	0	65535	RO
192	HR_SS_COLLECT_TIMESTAMP_UNIX_L		0	65535	RO
193	HR_SS_COLLECT_TIMESTAMP_MS	Timestamp of the requested download in milliseconds.	0	65535	RO
194	HR_SS_COLLECT_CHD_EVENT_INDEX	When an event occurs in the requested download, returns the index of the digital channel: 0 → No event. It is a periodic log 1 → Event on channel 1 2 → Event on channel 2 3 → Event on channel 3 4 → Event on channel 4 5 → Event on channel 5 6 → Event on channel 6	0	6	RO
195	HR_SS_COLLECT_CHD_EVENT_TYPE	When an event occurs in the requested download, returns the event type: 0 → No event. It is a periodic log 1 → Falling edge event of the digital channel 2 → Rising edge event of the digital channel	0	2	RO
196	HR_SS_COLLECT_CHD1_VALUE_H	Value of digital channel 1 in the requested download.	0	65535	RO
197	HR_SS_COLLECT_CHD1_VALUE_L		0	65535	RO
198	HR_SS_COLLECT_CHD2_VALUE_H	Value of digital channel 2 in the requested download.	0	65535	RO
199	HR_SS_COLLECT_CHD2_VALUE_L		0	65535	RO
200	HR_SS_COLLECT_CHD3_VALUE_H	Value of digital channel 3 in the requested download.	0	65535	RO
201	HR_SS_COLLECT_CHD3_VALUE_L		0	65535	RO
202	HR_SS_COLLECT_CHD4_VALUE_H	Value of digital channel 4 in the requested download.	0	65535	RO
203	HR_SS_COLLECT_CHD4_VALUE_L		0	65535	RO
204	HR_SS_COLLECT_CHD5_VALUE_H	Value of digital channel 5 in the requested download.	0	65535	RO
205	HR_SS_COLLECT_CHD5_VALUE_L		0	65535	RO
206	HR_SS_COLLECT_CHD6_VALUE_H	Value of digital channel 6 in the requested download.	0	65535	RO
207	HR_SS_COLLECT_CHD6_VALUE_L		0	65535	RO

ADDRESS	REGISTER	DESCRIPTION	MINIMUM VALUE	MAXIMUM VALUE	TYPE
208	HR_SS_COLLECT_CH1_SENSE_USER_RANGE_H	Displays the sensor value in the user range of analog channel 1 (in Float).	0	65535	RO
209	HR_SS_COLLECT_CH1_SENSE_USER_RANGE_L		0	65535	RO
210	HR_SS_COLLECT_CH2_SENSE_USER_RANGE_H	Displays the sensor value in the user range of analog channel 2 (in Float).	0	65535	RO
211	HR_SS_COLLECT_CH2_SENSE_USER_RANGE_L		0	65535	RO
		Reserved.			
216	HR_SS_WIFI_RSSI_MIN	Minimum value indicated by the HR_WIFI_RSSI register. You can reset the value using the HR_RESET_DIAG_RSSI register.	0	65535	RO
217	HR_SS_WIFI_RSSI_MAX	Maximum value indicated by the HR_WIFI_RSSI register. You can reset the value using the HR_RESET_DIAG_RSSI register.	0	65535	RO
218	HR_SS_WIFI_RSSI_AVERAGE	Average value indicated by the HR_WIFI_RSSI register. You can reset the value using the HR_RESET_DIAG_RSSI register.	0	65535	RO
		Reserved.			
221	HR_RESET_COUNTER_WDT	Resets the system Watchdog diagnostic counters.	0	1	RW
222	HR_RESET_COUNTER_LOGS	Resets the system logs diagnostic counters.	0	1	RW
223	HR_RESET_DIAG_RSSI	Resets the minimum, maximum and average signal quality (RSSI) measurement	0	1	RW

Table 10 – Registers table

ELEKTRO
VÁLVULAS
 SEGURIDAD Y CONTROL EN COMBUSTIÓN

NXperience software is the main tool to configure and perform the **DigiRail OEE** diagnosis and allows you to explore all the device features, communicating through its USB interface or via Modbus-TCP. However, **NXperience** is not a supervisory system and has no MQTT Broker functionality. You must use appropriate systems for the application to enjoy all the benefits provided by the device.

This manual describes the generic functionalities of the software. For more information, check the specific operations manual. The software can be downloaded free of charge from our website www.novusautomation.com, in the Download Area.

8.1 CONFIGURING DIGIRAIL OEE WITH NXPERIENCE

You can configure **DigiRail OEE** by clicking the **Configure** button, located on the **NXperience** home screen. The following sections describe each of the parameters that can be configured and their particularities.

8.1.1 GENERAL SETTINGS

Figure 19 – General settings

INFORMATION

- **Device Tag:** Allows you to configure a tag for the device. The field allows up to 20 characters.
- **Location:** Allows you to inform the place where the device has been positioned. The field allows up to 40 characters.
- **Serial Number:** Displays the device serial number.
- **Model:** Displays the device model.
- **Firmware Version:** Displays the device firmware version.
- **MAC Address:** Displays the device MAC address.

CLOUD APPLICATION

- **Cloud Type:** Allows you to configure the type of cloud to be used: Generic, LiveMES or MInA. By selecting the "LiveMES" or "MInA" option, besides configuring the device with the LiveMES or Mina communication standards, it is possible to leave the options "Configure channels defaults" and/or "Configure the publishing interval defaults" checked, to apply the settings for these cloud types, as shown in the figure below:

Figure 20 – LiveMES settings

CLOCK

- **Date/Time:** Displays the date and time of the Windows system, which will be used by **NXperience** to set the device clock when sending the configuration.
- **GMT:** Allows you to configure the GMT of the place where the device will be used (preferably during the first use).
- **NTP Server:** Once enabled, allows you to perform automatic clock synchronization through an NTP server.
 - **Address:** If the "NTP Server" option is enabled, allows you to set an address for the NTP server and thus update the clock automatically.

- **Difference to update:** If the "NTP Server" option is enabled, the clock will be updated whenever the difference between the clock of the NTP server and the device are greater than the value set in the parameter.

8.1.2 COMMUNICATION

This screen is divided into the following tabs: Ethernet or Wi-Fi, Modbus-TCP Protocol, MQTT Protocol, and RS485.

ETHERNET

This tab is specific to **DigiRail OEE – ETH** model.

The screenshot shows the 'Connections' configuration page for 'DigiRail OEE Validable'. The 'Ethernet' tab is selected. The configuration is as follows:

Parameter	Value
Obtaining address:	Static
IP Address:	192 . 168 . 1 . 100
Network Mask:	255 . 255 . 255 . 0
Default Gateway:	192 . 168 . 1 . 1
DNS Server:	8 . 8 . 8 . 8
IPv6 address:	2803 : 49b4 : 0d47 : 8c09 : 305e : bc4c : 614b : 3089
DNS Server:	2001 : 4860 : 4860 : 0000 : 0000 : 0000 : 0000 : 8844
Prefix:	64

Figure 21 – Ethernet model

- **Obtaining Address:** Allows you to configure the way in which **DigiRail OEE - ETH** will acquire an IP: DHCP (Dynamic Host Configuration Protocol), protocol that allows the IP address (Internet Protocol) to be assigned by the network server, or Static, which allows the user to define the IP address, the subnet mask, and the default gateway for the connection. In this case, it is also necessary to define the DNS (Domain Name System) server. By default, the device is configured with the "DHCP" setting.
- **IPv4 Configuration:**
 - **IP Address:** Allows you to configure the IP address. This parameter refers to the identification of the device in a local or public network. Each computer or device on the Internet or in an internal network has a unique IP. It is a mandatory field when the **Obtaining Address** parameter is set to "Static".
 - **Network Mask:** Allows you to configure the network mask. This parameter allows you to divide a specific network into smaller subnets, optimizing the use of a certain IP range. It is a mandatory field when the **Obtaining Address** parameter is set to "Static".
 - **Default Gateway:** Allows you to define the gateway to be used. This parameter refers to the address that connects the device to the Internet. It is a mandatory field when the **Obtaining Address** parameter is set to "Static".
 - **DNS Server:** Allows you to define the DNS server. This parameter refers to a hierarchical and distributed name management system for computers, services or any resource connected to the Internet or to a private network. It is a mandatory field when the **Obtaining Address** parameter is set to "Static".
- **IPv6 Configuration:**
 - **IP Address:** Allows you to configure the IPv6 address. This parameter refers to the identification of the device in a local or public network. Each computer or device on the Internet or in an internal network has a unique IP. It is a mandatory field when the **Obtaining Address** parameter is set to "Static".
 - **DNS Server:** Allows you to configure the DNS server. This parameter refers to a hierarchical and distributed name management system for computers, services or any resource connected to the Internet or to a private network. It is a mandatory field when the **Obtaining Address** parameter is set to "Static".
 - **Prefix:** Allows you to configure the prefix to be used.

WI-FI

This tab is specific to **DigiRail OEE – WRL** model.

The screenshot shows the 'Connections' configuration page for the NOVUS DigiRail OEE. The 'Wi-Fi' tab is selected. The configuration fields are as follows:

Field	Value
Access point SSID	NOVUS
Access point password	••••••
Obtaining address	Static
IP Address	192 . 168 . 0 . 11
Network Mask	255 . 255 . 0 . 0
Default Gateway	192 . 168 . 0 . 1
DNS Server	200 . 1 . 2 . 3
IPv6 address	2803 : 49b4 : 0d47 : 8c09 : 305e : bc4c : 614b : 3089
DNS Server	2001 : 4860 : 4860 : 0000 : 0000 : 0000 : 0000 : 8844
Prefix	15

Figure 22 – Wi-Fi Model

- **Wi-Fi Configuration:**

- **Access Point SSID:** Allows you to enter the name of the Wi-Fi network to which **DigiRail OEE – WRL** will try to connect to. The field allows up to 32 alphanumeric characters.
- **Access Point Password:** Allows you to enter the Wi-Fi network password to which **DigiRail OEE – WRL** will try to connect to. The field allows up to 21 alphanumeric characters.

From firmware version 1.02 forward, **DigiRail OEE** leaves the factory pre-configured to connect to an Access Point with SSID "DROEE" and password "digirail-oe". If the user has several **DigiRail OEE** to configure, simply configure an Access Point with that SSID and password (or put the smartphone to route the Wi-Fi) so that they all connect. This way, the user will not need to configure each of the devices through the USB interface. A new SSID and password configuration can be done either by USB or by Modbus TCP, through the **NXperience** software, or even through the MQTT protocol.

- **Obtaining Address:** Allows you to configure the way in which **DigiRail OEE – WRL** will acquire an IP: DHCP (Dynamic Host Configuration Protocol), protocol that allows the IP address (Internet Protocol) to be assigned by the network server, or Static, which allows the user to define the IP address, the subnet mask, and the default gateway for the connection. In this case, it is also necessary to define the DNS (Domain Name System) server. By default, the device is configured with the "DHCP" setting.

- **IPv4 Configuration:**

- **IP Address:** Allows you to configure the IP address. This parameter refers to the identification of the device in a local or public network. Each computer or device on the Internet or in an internal network has a unique IP. It is a mandatory field when the **Obtaining Address** parameter is set to "Static".
- **Network Mask:** Allows you to configure the network mask. This parameter allows you to divide a specific network into smaller subnets, optimizing the use of a certain IP range. It is a mandatory field when the **Obtaining Address** parameter is set to "Static".
- **Default Gateway:** Allows you to define the gateway to be used. This parameter refers to the address that connects the device to the Internet. It is a mandatory field when the **Obtaining Address** parameter is set to "Static".
- **DNS Server:** Allows you to define the DNS server. This parameter refers to a hierarchical and distributed name management system for computers, services or any resource connected to the Internet or to a private network. It is a mandatory field when the **Obtaining Address** parameter is set to "Static".

- **IPv6 Configuration:**

- **IP Address:** Allows you to configure the IPv6 address. This parameter refers to the identification of the device in a local or public network. Each computer or device on the Internet or in an internal network has a unique IP. It is a mandatory field when the **Obtaining Address** parameter is set to "Static".
- **DNS Server:** Allows you to configure the DNS server. This parameter refers to a hierarchical and distributed name management system for computers, services or any resource connected to the Internet or to a private network. It is a mandatory field when the **Obtaining Address** parameter is set to "Static".
- **Prefix:** Allows you to configure the prefix to be used.

MODBUS-TCP PROTOCOL

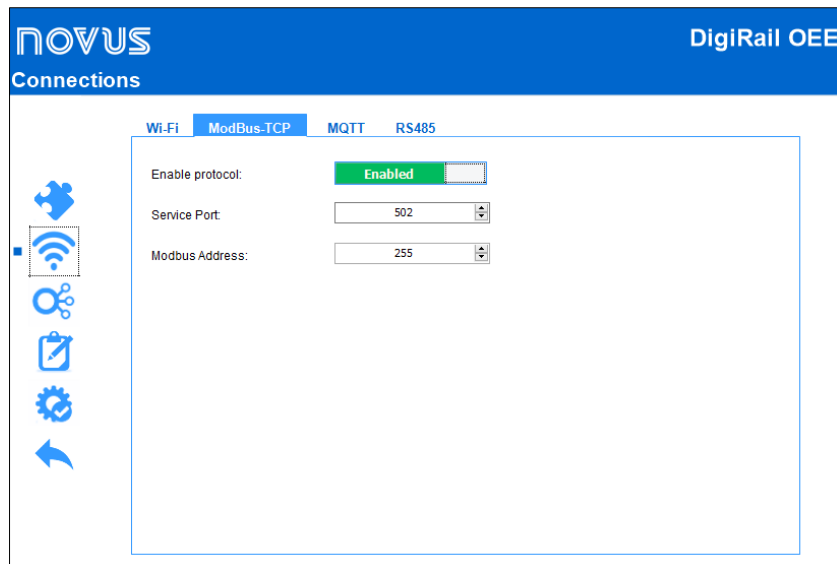

Figure 23 – Modbus-TCP protocol

- **Enable Protocol:** Allows you to enable or disable the Modbus-TCP service.
- **Service Port:** Allows you to configure the TCP port on which the service will be available.
- **Modbus Address:** Allows you to configure the Modbus RTU address at which the device will reply as a server (slave). In cases of packets with address that diverge from the configured value, the device will operate as a Gateway.

MQTT PROTOCOL



Figure 24 – MQTT Protocol

- **Enable MQTT:** Allows you to enable or disable the sending of data via the MQTT protocol.
- **Cloud:** Allows you to configure the platform to be used during the connection with the MQTT Broker: Generic platform, Google Cloud, Amazon AWS, Microsoft Azure, **NOVUS Cloud**, LiveMES or MInA. Depending on the option chosen, the parameters will adjust to meet the specific requirements of the platform. To customize all the parameters, select the "General" option. When you select the "LiveMES" or "MInA" option, the device will set the platform defaults. You do not need to make any changes to use the MQTT protocol.
- **Broker User:** Allows you to configure the user registered in the Broker. This field allows up to 32 characters. If the field is empty, the connection will be made in anonymous mode. Parameter not necessary for Google Cloud and Microsoft Azure.
- **Broker Password:** Allows you to configure the password of the user registered in the Broker. This field allows up to 42 characters. If the field is empty, the connection will be made in anonymous mode. Parameter not necessary for Google Cloud and Microsoft Azure.
- **Service Port:** Allows you to configure the number of the port used to make the connection with the Broker.
- **QoS:** Allows you to configure the quality level of service used to send MQTT messages: 0 or 1.
- **Data Retention:** Allows you to configure whether data should be retained in the cloud. Not all platforms support this feature.
- **Broker URL or IP:** Allows you to configure the Broker address, which can be either a URL (Uniform Resource Locator) or an IP. The field allows up to 60 characters.
- **Device ID:** Allows you to configure a device ID.
- **Project ID:** Allows you to configure a project ID. Parameter exclusive to Google Cloud.

- **Register ID:** Allows you to configure a register ID. Parameter exclusive to Google Cloud.
- **Region:** Allows you to configure a region for the connection: "Us-central1", "Europe-west1" or "Asia-east1". Parameter exclusive to Google Cloud.
- **Topics:** By clicking the **Edit** button, you can enter the topics to be used for the connection:

Figure 25 – Topics

- **Publishing Topics:** Allows you to configure the device to publish data in the cloud. For more information on publication topics, check the [PUBLICATION AND SUBSCRIPTION TOPICS](#) section of the [MQTT PROTOCOL](#) chapter.
 - Topic to publish periodic data and events
 - Topic to confirm the configuration
 - Topic to confirm the command
- **Subscription Topics:** Allows you to configure the device to receive data in the cloud. For more information on subscription topics, check the [PUBLICATION AND SUBSCRIPTION TOPICS](#) section of the [MQTT PROTOCOL](#) chapter.
 - Topic to receive the configuration
 - Topic to receive the commands
- **Primary Key:** Allows you to configure the primary key to be used. Parameter exclusive to Microsoft Azure.
- **Security:** Allows you to configure the protocol and data encryption for secure communication with the MQTT Broker.
 - **None:** The connection does not use security measures.
 - **Only TLS V 1.2 - CA:** If this option is selected, communication with the Broker will use the Transport Layer Security (TLS) 1.2 protocol, which requires a TLS certificate recognized by a certification authority (CA) to ensure privacy and data integrity.
 - **TLS V 1.2 - Self Signed:** If this option is selected, communication with the Broker will use the Transport Layer Security (TLS) 1.2 protocol, which, in addition to the TLS certificate recognized by a certification authority (CA), also requires authentication of the client certificate and its private key to ensure privacy and data integrity.

Note: CA certificate, client certificate and private key files are accepted in .pem and .der formats only.
- **Save the certificate to the configuration file:** Once enabled, adds the certificate contents whenever you save a configuration file.
- **Read the certificate via Modbus-TCP:** Once enabled, allows **NXperience** to read certificates via the Modbus-TCP interface.
- **Publish Diagnostics Periodically:** By enabling this parameter, **DigiRail OEE** will perform periodic diagnostic publications in the command confirmation topic. It will be published whenever the device is started and every day at midnight (if connected to the Broker). There will be two publications: One with the "diag" object with the system event counts and another with the "logs" object, returning the last 50 system events.

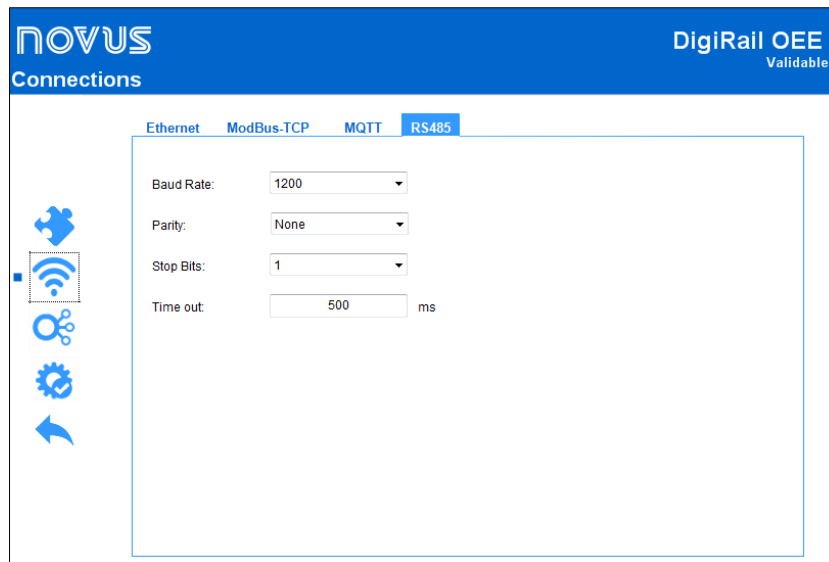

Figure 26 – RS485

- **Stop Bits:** Allows you to configure the number of Stop Bits to be used by the RS485 interface.
- **Baud Rate:** Allows you to configure the Baud Rate to be used by RS485: 1200, 2400, 4800, 9600, 19200, 38400, 57600 or 115200.
- **Parity:** Allows you to configure the parity to be used by the RS485 interface: Even, odd or none.
- **Timeout:** Allows you to configure a period (in ms) to be used by the RS485 interface to define how long the device will wait for a response from a network slave. This parameter may be configured with a minimum value of 10 ms and a maximum value of 65535 ms.

8.1.3 CHANNELS

ANALOG CHANNELS

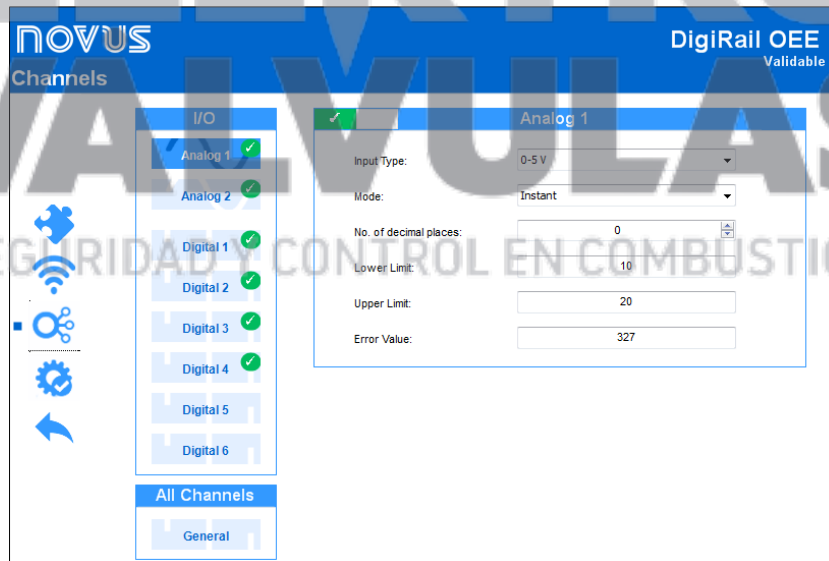

Figure 27 – Analog channels

- **Input Type:** Allows you to configure the type of sensor to be used on each analog channel.
- **Number of decimal places:** Allows you to configure the number of decimal places to be used when publishing the calculated value.
- **Lower Limit:** Allows you to configure a minimum value for the sensor.
- **Upper Limit:** Allows you to configure a maximum value for the sensor.
- **Error Value:** Allows you to configure the error value to be considered for the display when an error is detected while reading the sensor.

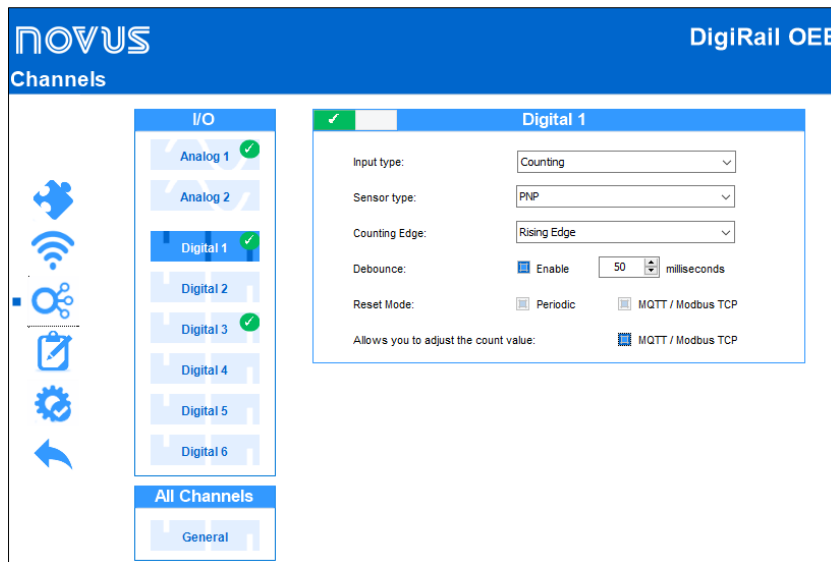

Figure 28 – Digital channels

- **Input Type:** Allows you to configure the type of digital input: Counting or Event.
- **Sensor Type:** Allows you to configure the type of sensor to be used: PNP, NPN or Dry Contact.
- **Counting Edge:** Allows you to configure the desired counting edge: Rising edge, falling edge or both edges. This way, the device will increase the counts or recognize an event whenever the configured edge is detected in the digital input.
- **Debounce:** Once enabled, allows you to configure the debounce period to be used. The debounce refers to the sensor settling time (minimum time in which the sensor must remain at the logical level of interest so that the detected edge is considered valid).
- **Reset Mode:** Allows you to configure the reset mode of the selected channel: Periodic and/or MQTT/Modbus TCO. You can set the Periodic mode on the ALL CHANNELS tab (see the [ALL CHANNELS](#) section of this chapter).
- **Allows you to adjust the count value:** Once enabled, allows changes via Modbus/MQTT in the channel digital counter.

ALL CHANNELS

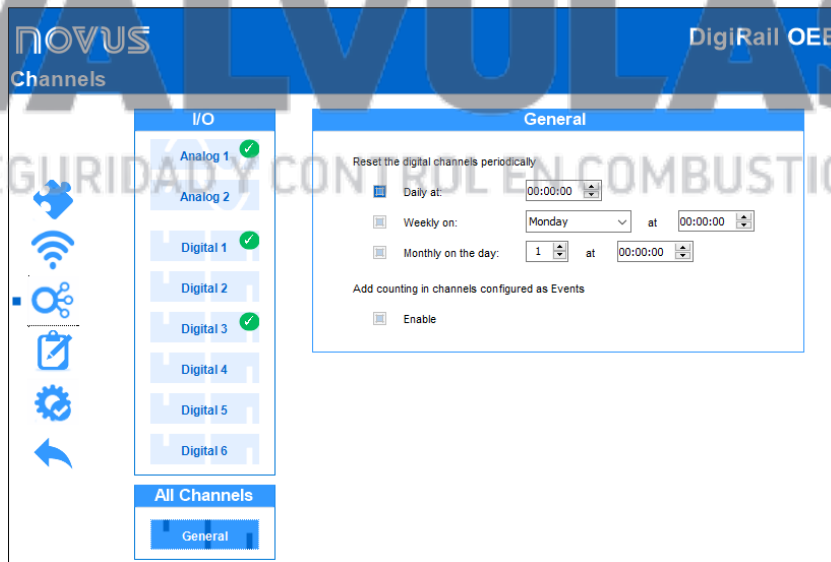

Figure 29 – All channels

RESET THE DIGITAL CHANNELS PERIODICALLY

It allows you to configure the periodic reset mode of the digital channels configured in "Periodic" mode (see the [CHANNELS](#) section of this chapter).

ADD COUNTING IN CHANNELS CONFIGURED AS EVENT

When the digital channel is configured as "Event", it allows you to add the count value in the circular buffer and in the MQTT publication.

8.1.4 LOGS

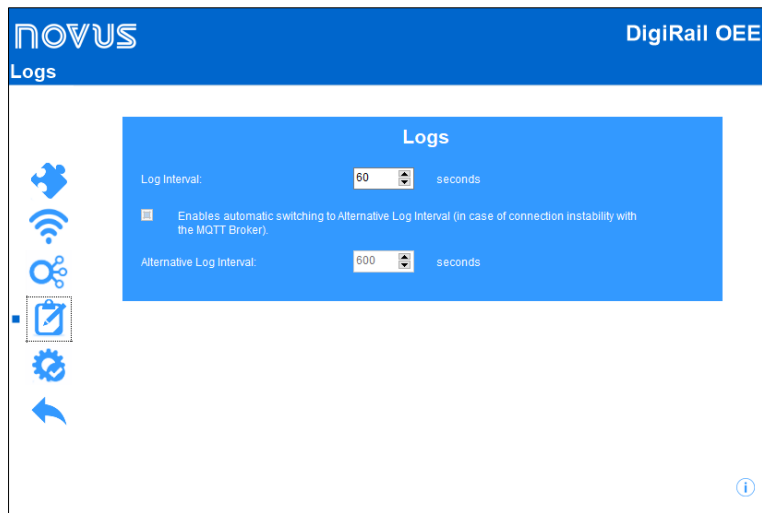

Figure 30 – Logs

- **Log Interval:** Allows you to define the interval (in seconds) at which the data will be logged to the circular buffer. If the MQTT protocol is enabled, this interval will also be used to log the periodic data publications.
- **Automatic switch to Alternative Log Interval:** Once enabled, allows increasing the time interval in which the data will be logged in the memory in cases of instability of the connection with the MQTT Broker. When the MQTT publication submission queue is greater than 10% of capacity, the log interval will be changed to the value set in the "Alternative Log Interval" parameter. When the connection is restored and the queue is below 10 % of capacity, the log range is reset.
- **Alternative Log Interval:** Allows you to define the interval (in seconds) to be used when the MQTT publish sending queue is over 10% of capacity. In this case, the option "Enables automatic switching to Alternative Log" must be enabled.

8.2 DIAGNOSTICS

You can view the DigiRail OEE diagnosis tab by clicking the **Diagnostics** button located on the **NXperience** home screen.

8.2.1 INFORMATION

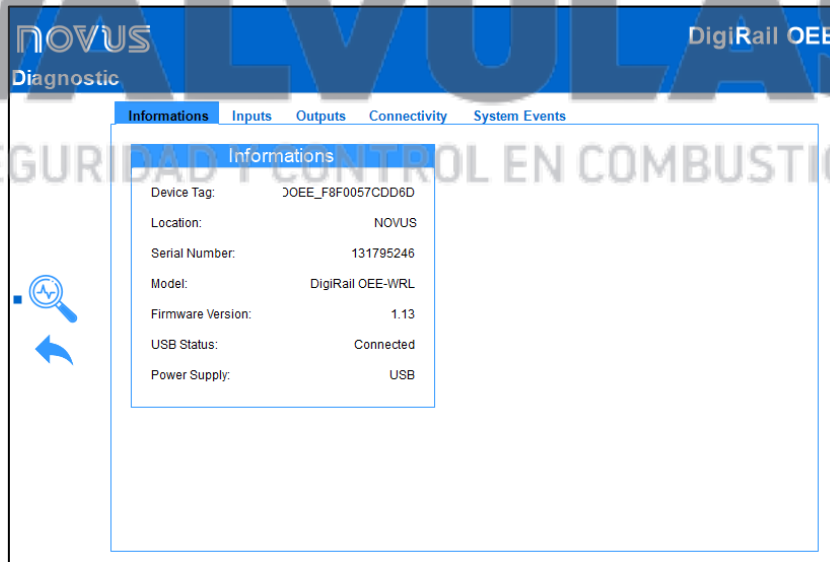

Figure 31 – General configuration

- **Device Tag:** Displays the device tag.
- **Location:** Displays the location of the device, as configured in the General Information section of the Configuration tab (see [CONFIGURING DIGIRAIL OEE WITH NXPERIENCE](#) section of this chapter).
- **Serial Number:** Displays the device serial number.
- **Model:** Displays the device model.
- **Firmware Version:** Displays the device current firmware version.
- **USB Status:** Displays the USB interface status of the device.
- **Power Supply:** Displays information about the power supply status of the device.

8.2.2 INPUTS

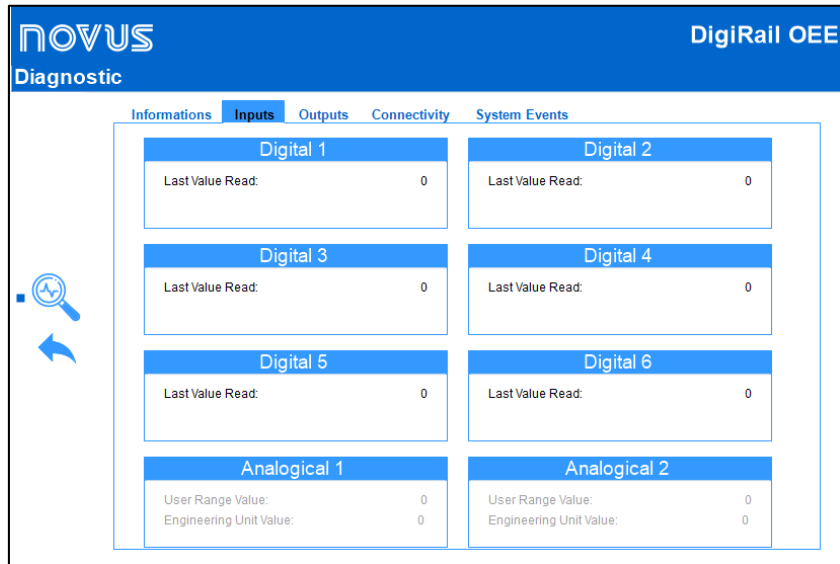

Figure 32 – Inputs diagnostics

- **Value:** Displays the current value of the configured channel. When the channel has been configured as "Event", this field will show the value 0 or 1. When the channel has been configured as "Counting", it will show the counter value.
- **Date/Time:** Displays the date and time of an event if the digital input has been configured in "Event" mode (see the [DIGITAL CHANNELS](#) section of this chapter).
- **Engineering Unit Value:** Displays the value measured by the channel in V or mA, depending on the type of channel configured.

8.2.3 OUTPUTS



Figure 33 – Output diagnostics

This section allows you to force outputs 1 and 2 in on or off status by clicking the **On** button, in addition to displaying the status of each output.

8.2.4 CONNECTIVITY

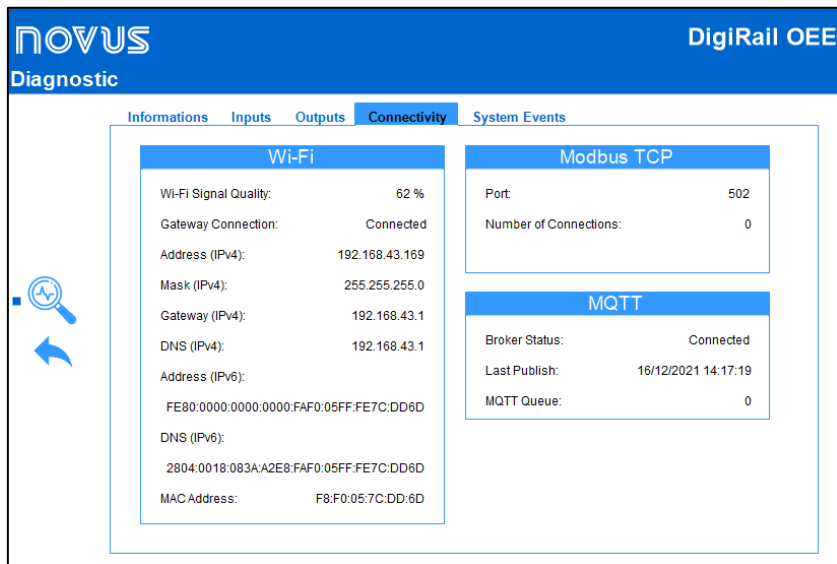

Figure 34 – Connectivity

ETHERNET

This section will present parameters related to the device model: **DigiRail OEE – ETH** or **DigiRail OEE – WRL**.

- **Wi-Fi Quality:** Displays the quality of the Wi-Fi signal in percentage value.
- **Gateway Connection:** Displays information on the status of the Gateway connection.
- **IPv4 - Address:** Displays the device IPv4 address.
- **IPv4 - Mask:** Displays the device IPv4 mask.
- **IPv4 - Gateway:** Displays the device Gateway.
- **IPv4 - DNS:** Displays the device DNS.
- **IPv6 - Local:** Displays the device local IPv6 address.
- **IPv6 - Global:** Displays the device global IPv6 address.
- **MAC Address:** Displays the device MAC address.

MODBUS-TCP

- **Port:** Displays the number of the Modbus-TCP port configured in the device.
- **Number of Connections:** Displays the number of Modbus-TCP Clients currently connected to the device.

MQTT

- **Broker Status:** Displays the connection status to the configured MQTT Broker.
- **Last Update:** Displays the day and time of the last package successfully published in the MQTT Broker.
- **MQTT Queue:** Displays the number of logs awaiting publication.

8.2.5 SYSTEM EVENTS

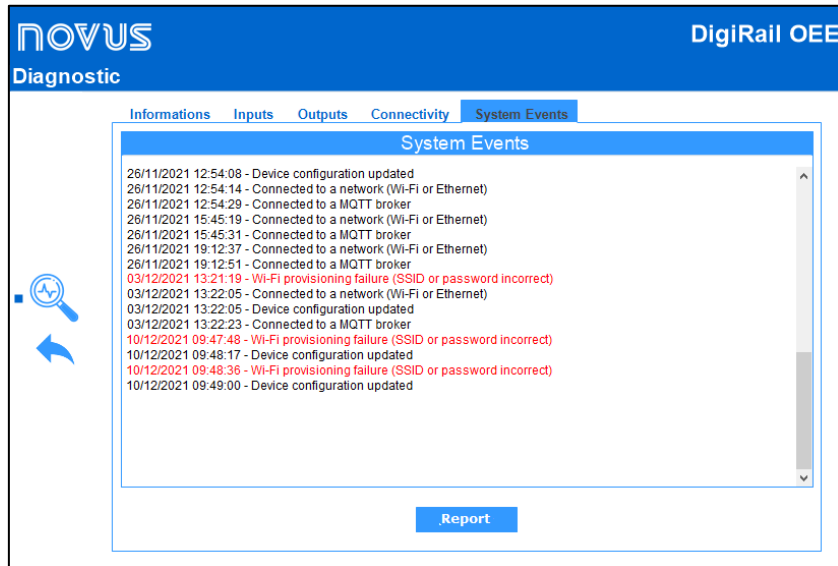

Figure 35 – System events

This section allows you to view the system events. In addition, you can generate a report with extension .CSV, which contains the event log and a count of how many times each event occurred.

ELEKTRO
VÁLVULAS
SEGURIDAD Y CONTROL EN COMBUSTIÓN

9 TECHNICAL SPECIFICATION

FEATURES	DIGIRAIL OEE	
Input Channels	6 digital inputs and 2 analog inputs	
Compatible Analog Signals	0-5 V, 0-10 V, 0-20 mA, 4-20 mA	
Analog Input Resolution	15 bits	
Analog Channels Input Impedance	mA: 15 Ω + 1.5 V V: 1 M Ω	
Accuracy	0.15 % (F.S.)	
Digital Input	Logical Level	Logical level "0": < 0.5 V Logical level "1": > 3 V
	Maximum Voltage	30 V
	Input Impedance	270 k Ω
	Input Current @ 30 Vcc (Typical)	0.15 mA
	Maximum Frequency (Square wave)	Dry Contact: < 10 Hz PNP: 3 kHz NPN: 3 kHz
	Minimum Pulse Length	Dry Contact: 50 ms PNP: 150 us NPN: 150 us
Digital Output	2 digital NPN outputs Maximum current that can be switched at the output: 700 mA	
Buffer Capacity	<ul style="list-style-type: none"> 7000 logs with 1 analog input enabled* 1800 logs with 2 analog inputs enabled and the 6 digital inputs in Count mode* 	
Communication Interfaces	DigiRail OEE – ETH	<ul style="list-style-type: none"> USB 2.0 Interface Ethernet Interface (10/100 Mbps) with RJ45 connector RS485 communication interface with Modbus RTU protocol in Gateway mode
	DigiRail OEE – WR	<ul style="list-style-type: none"> USB 2.0 Interface Wi-Fi Interface (802.11 b/g/n 2.4 GHz), supporting WPA-Personal (PSK) WPA/WPA2 TKIP/AES/TKIP and AES encryption RS485 communication interface with Modbus RTU protocol in Gateway mode
LEDs	<ul style="list-style-type: none"> 1 x Status LED 1 x Local Network Connection LED 1 x Broker MQTT Connection LED 	
Software	NXperience (via USB or TCP/IP network for desktops and notebooks).	
Power Supply	Power Supply	Wi-Fi Model: Consumption: 70 mA @24V Consumption: 160 mA @12V
		Ethernet Model: Consumption: 50 mA @24V Consumption: 120 mA @12V
	Batteries	CR2032 battery for internal clock retention
Dimension	129 mm x 142 mm x 38 mm.	
Mounting	DIN rail or screw mounting.	
Environment	Operating Temperature: -20 to 60 °C (-4 to 140 °F) Storage Temperature: -20 to 60 °C (-4 to 140 °F) Humidity: 5 to 95 % RH (without condensation)	
Housing	ABS+PC	

FEATURES	DIGIRAIL OEE
Protection Index	IP20
Certification	ANATEL (09260-20-07089), CE, UKCA, FCC, Compatible with IEC 60068-2-6 (2007), Contains FCC ID: 2ADHKATWINC1500, Contains IC: 20266-WINC1500PB.

* None of the cases consider event log.

Table 11 – Technical Specification

9.1 CIRCULAR BUFFER AVAILABILITY TABLE

This table allows you to evaluate the maximum number of downloads performed by the enabled channels if the digital channel count is in event mode or if it is not in event mode.

DIGITAL CHANNELS	ANALOG CHANNELS	MAXIMUM AMOUNT (WITHOUT EVENT COUNTING)	MAXIMUM AMOUNT (WITH EVENT COUNTING)
0	1	7096	4913
0	2	5806	4913
1	0	5806	4913
2	0	4258	4258
3	0	3361	3361
4	0	2777	2777
5	0	2365	2365
6	0	2060	2060
6	1	1935	1935
6	2	1824	1824

Table 12 – Circular buffer availability

For more information about the operation and download of the circular buffer, see the document on the Modbus-TCP Protocol, available on the product page of the **NOVUS** website.

9.2 WIRELESS CONNECTIVITY

DigiRail OEE WRL has an embedded wireless connectivity module to communicate with Wi-Fi 2.4 GHz 802.11 b/g/n networks. The device uses an ATWINC1500-MR210PB Wi-Fi connectivity module from the Microchip manufacturer and allows data connectivity over Wi-Fi.

FEATURES	DESCRIPTION
WLAN standard	IEEE 802.11b/g/n (802.11b/g/n) Part
Frequency ranges	2.412 – 2.484 GHz

Table 13 – Supported WLAN standards

FEATURES	DESCRIPTION
Frequency ranges	2.412 – 2.484 GHz (2.4 GHz ISM Band)
Number of selectable subchannels	14 Channels
Modulation	802.11b: DBPSK, DQPSK, CCK 802.11g/n: OFDM/64-QAM, 16QAM, QPSK, BPSK
Supported rates	802.11b: 1, 2, 5.5, 11 Mbps 802.11g: 6, 9, 12, 18, 24, 36, 48, 54 Mbps 802.11n (20 MHz, normal GI, 800 ns): 6.5, 13, 19.5, 26, 39, 52, 58.5, 65 Mbps 802.11n (20 MHz, short GI, 400 ns): 7.2, 14.4, 21.7, 28.9, 43.3, 57.8, 65, 72.2 Mbps
Reception: Maximum sensibility	802.11b: -95 dBm @ 1 Mbps, -86 dBm @ 11 Mbps 802.11g: -90 dBm @ 6 Mbps, -74 dBm @ 54 Mbps 802.11n: -89 dBm @ MCS 0, -70.5 dBm @ MCS 7
Output: Maximum power	802.11b: 13.6 dBm @ 1 Mbps, 15.3 dBm @ 11 Mbps 802.11g: 18.9 dBm @ 6 Mbps, 14.3 dBm @ 54 Mbps 802.11n: 18.9 dBm @ MCS 0, 12.2 dBm @ MCS 7

Table 14 – WLAN specification of the Wi-Fi connectivity module

9.3 CERTIFICATION

ANATEL

This device is homologated by ANATEL, according to the regulated procedures for conformity assessment of telecommunications devices, and meets the technical requirements applied.

This equipment is not subject to the protection from harmful interference and may not cause interference with duly authorized systems.

For more information, see the ANATEL website www.anatel.gov.br.

FCC

Contains FCC ID: 2ADHKATWINC1500

This equipment has been tested and found to comply with the limits for a Class A digital device, pursuant to Part 15 of the FCC Rules. These limits are designed to provide reasonable protection against harmful interference when the equipment is operated in a commercial environment. This equipment generates, uses, and can radiate radio frequency energy and, if not installed and used in accordance with the instruction manual, may cause harmful interference to radio communications.

Any changes or modifications not expressly approved by the party responsible for compliance could void the user's authority to operate this equipment.

RF Exposure: To satisfy FCC RF exposure requirements, a separation distance of 6.5 cm or more should be maintained between the antenna of this device and persons during operation. To ensure compliance, operations at closer distances than this are not recommended. This device and its antenna(s) must not be co-located or operating in conjunction with any other antenna or transmitter.

This device complies with part 15 of the FCC Rules. Operation is subject to the following two conditions: (1) This device may not cause harmful interference, and (2) this device must accept any interference received, including interference that may cause undesired operation.

CE Mark / UKCA

This is a Class A product. In a domestic environment, this product may cause radio interference in which case the user may be required to take adequate measures.

IC

Contains IC: 20266-WINC1500PB

This device complies with Industry Canada's license exempt RSS standard(s). Operation is subject to the following two conditions:

- (1) This device may not cause interference, and
- (2) This device must accept any interference, including interference that may cause undesired operation of the device.

The installation of the transmitter must ensure that the antenna has a separation distance of at least 6.5 cm from all persons or compliance must be demonstrated according to the ISED SAR procedure

VIBRATION TESTS

The device is in accordance with the vibration tests in the profile described in IEC 60068-2-6 (2007) - Environmental Testing - Part 2: Tests - Test Fc: Vibration (Sinusoidal).

Warranty conditions are available on our website www.novusautomation.com/warranty.

ELEKTRO VÁLVULAS

SEGURIDAD Y CONTROL EN COMBUSTIÓN

11.1 PURPOSE

Due to the high levels of electromagnetic noise caused by machinery in industrial environments, digital devices can be susceptible to electromagnetic interference. Because of this, good practices should be adopted during the installation of electronic devices to mitigate the effects of this interference.

This appendix presents some recommendations for the installation of digital sensors and is intended to prevent data acquisition problems.

11.2 BEST PRACTICES FOR INDUSTRIAL INSTALLATION

A proper installation must have an industrial grounding system that complies with the IEC 60364-1. This is necessary to ensure the reduction of interference caused by industrial machinery and the equipotentialization between the supply voltages of electronic devices.

Along with the grounding system, it is recommended to choose a good DC 24 V power supply, which guarantees isolation and interference filtering from the AC power input to the DC 24 V power output. CE Mark certified power supplies are the most suitable.

Some manufacturing plants have machines that produce excessive electromagnetic interference. For these cases, it is recommended to choose an instrumentation panel where the electronic devices can be installed. It must comply with the technical standards and provide the shielding of the industrial environment through a grounding terminal that must be connected to the grounding system.

An important recommendation for the proper functioning of the system is to ensure that the cabling between sensors and instrumentation devices has the best path in the manufacturing plant to obtain the shortest distance between instruments and sensors and, at the same time, distance them from possible sources of electromagnetic interference (machines, motors, and sources of electromagnetic pulses). It is recommended that instrumentation sensors run through the plant through grounded conduits exclusively for instrumentation. The power supply network of the machines must run through the plant in separate conduits.

11.3 INSTALLATION RECOMMENDATIONS FOR DIGIRAIL OEE DIGITAL INPUT SIGNALS

In most cases, following good industrial installation practices, described in the previous section, is enough to ensure that the system will work properly. However, depending on the environment where the device is installed, some extra recommendations may be necessary.

11.3.1 ISOLATED GROUND POWER SUPPLY

The figure below illustrates how to connect a power supply to DigiRail OEE, a Dry Contact type sensor on digital channel 1, an NPN type sensor on digital channel 2 and a PNP type sensor on digital channel 3. In this example we also show that the power supply must be grounded.

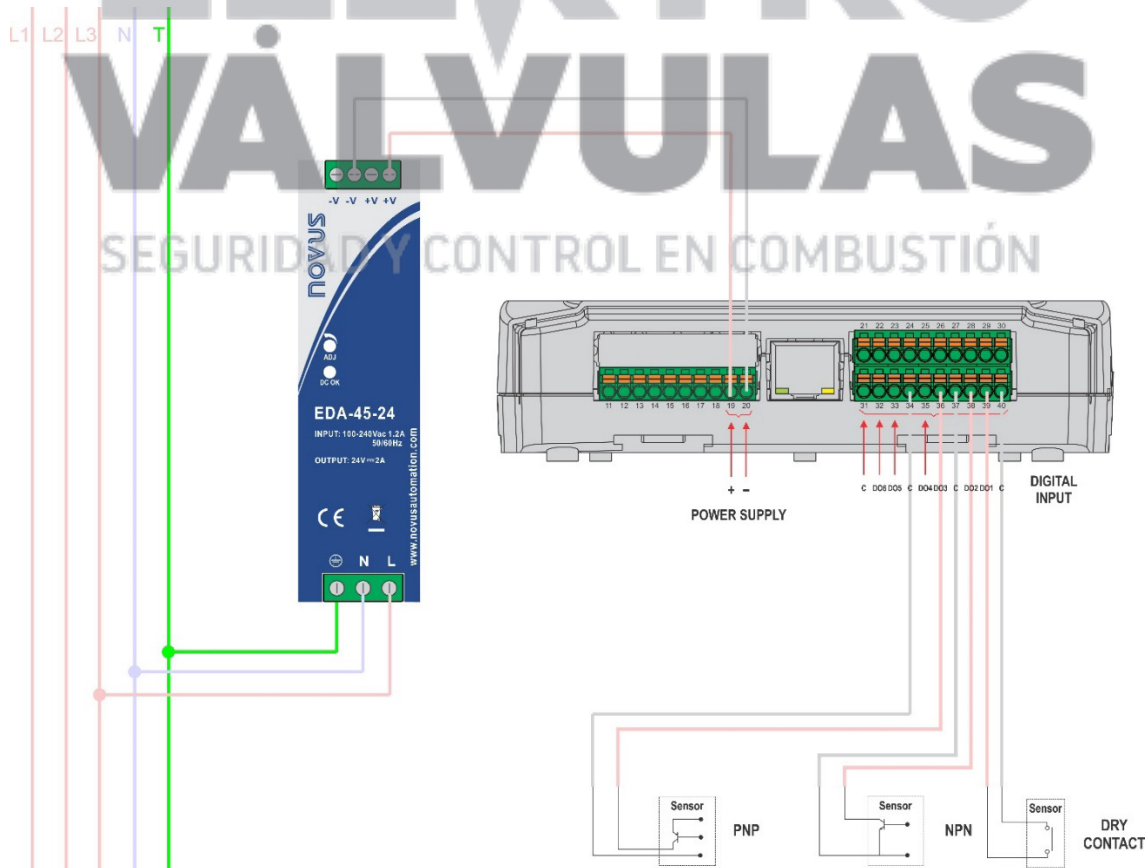

Figure 36 – Isolated ground power supply

11.3.2 PULL-UP RESISTORS FOR THE SENSORS

If the previous recommendation has been implemented and there is still a problem reading the sensors, pull-up resistors can be used to improve the sensor signal. Dry Contact and NPN sensors should have the sensor reading signal connected to the positive side of the power supply through a 10 kohm ¼ W resistor.

PNP type sensors should have the sensor reading signal connected to the negative of the power supply through a 10 kohm ¼ W resistor (a pull-down resistor). This procedure is used to improve the sensor signal when the sensor is open.

The pull-up and pull-down resistors can be connected either close to the device or close to the sensors. The figure below shows how to connect each of these sensors.

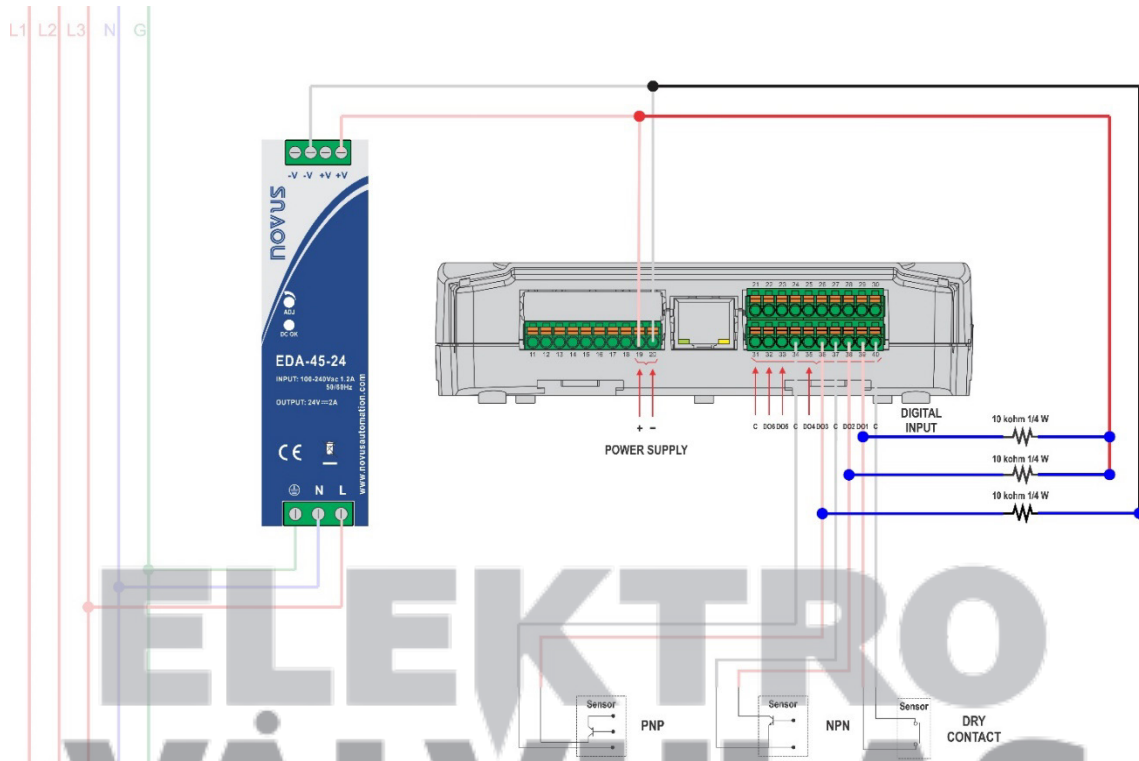

Figure 37 – Pull-up resistors

11.3.3 HOW TO GROUND THE NEGATIVE TERMINAL OF THE POWER SUPPLY

If none of the previous implementations has solved the problem, it is possible that there is a potential difference between the negative terminal of the power supply and the system ground, and a current leakage in one of the connected sensors. You can ground the negative terminal of the power supply to eliminate these problems.

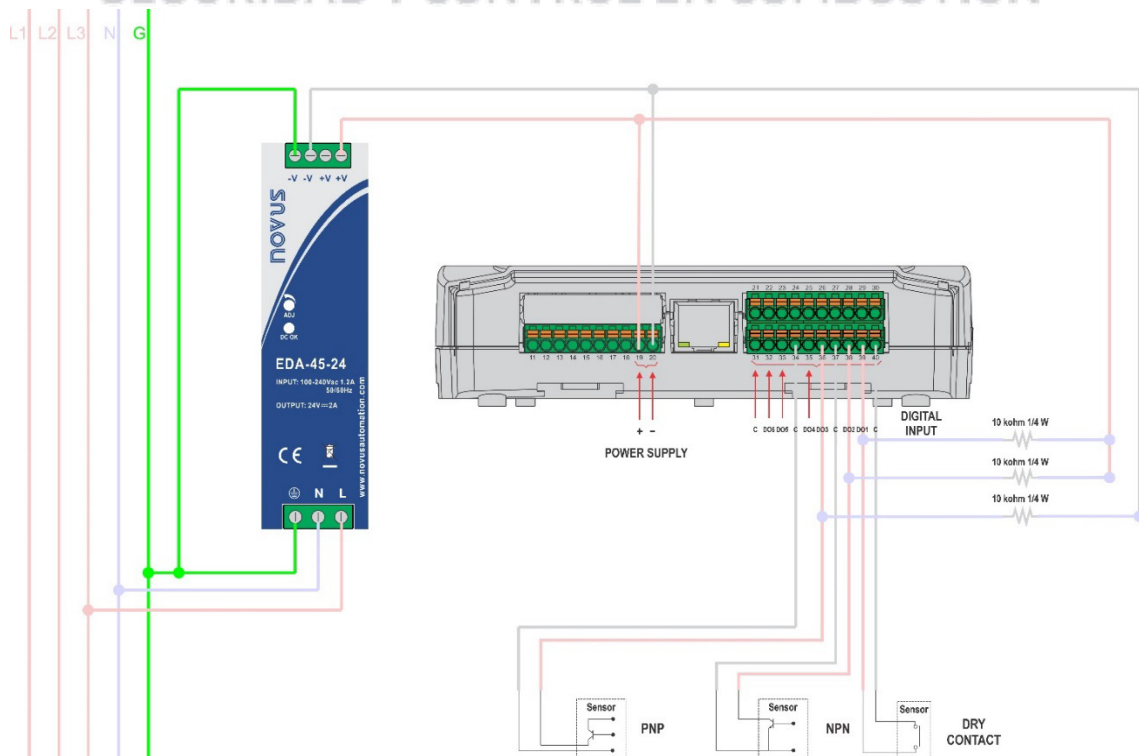

Figure 38 – Ground the negative terminal of the power supply

11.3.4 GROUNDED CONDUIT

A good installation practice that prevents possible problems in reading the sensors is to use grounded conduit between the device and sensors. The figure below shows how to use grounded conduit in the path where the sensor signals travel through the plant.

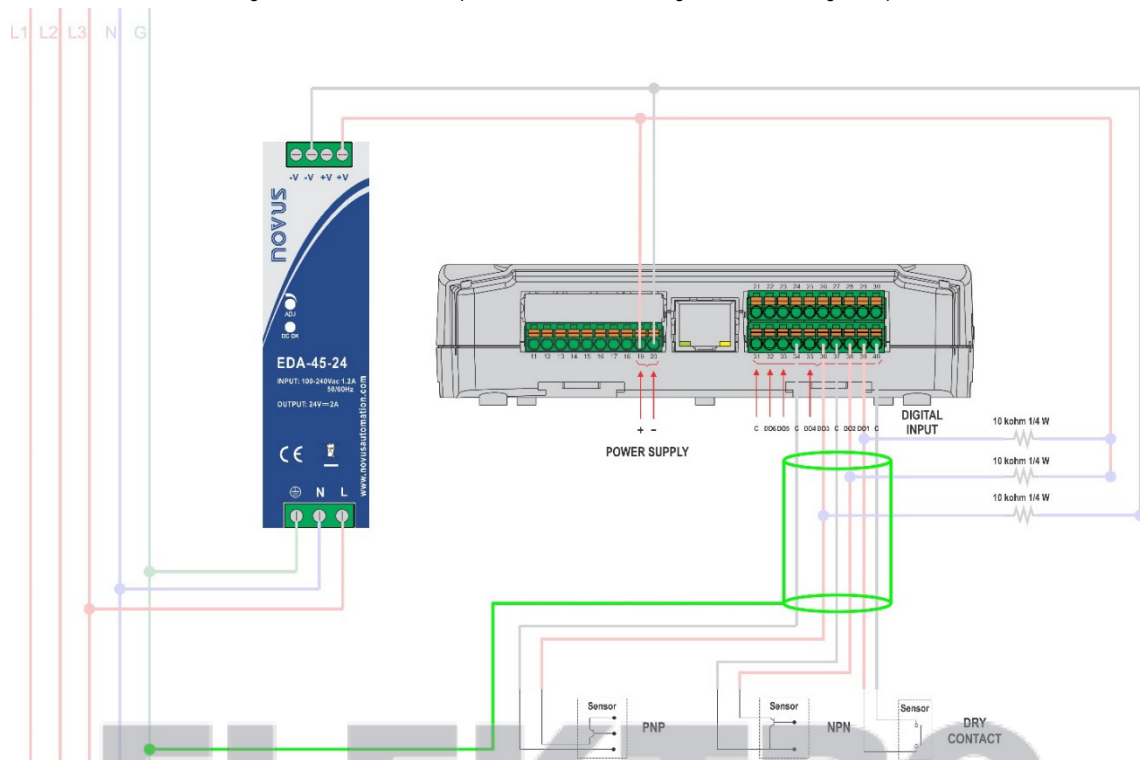

Figure 39 – Grounded conduit

**ELEKTRO
VÄLVULAS**
SEGURIDAD Y CONTROL EN COMBUSTIÓN